

Smart Hearing Aid for Blind Device (SHABD)

Prof. E. R. Chandane¹, Prajakta Santosh Dhage², Aarti Balbhim Kamble³,
Akhila Shriniwas Boddu⁴, Ankita Durgadas Bolabattin⁵

¹ Assistant Professor, Department of Electronics and Telecommunication Engineering,

²⁻⁵ Students, Department of Electronics and Telecommunication Engineering,

Shree Siddheshwar Women's College of Engineering, Solapur, Maharashtra, India

Abstract: *Visually impaired individuals often face significant challenges in accessing printed information independently in their daily lives. Reading books, newspapers, medicine labels, and official documents generally requires external support. Existing assistive technologies are often expensive, complex, and dependent on smartphones or advanced hardware. This paper presents a Blind Reader Assistance System using ESP32-CAM, Optical Character Recognition (OCR), and Text-to-Speech (TTS) technology to assist visually impaired individuals in reading printed text independently. The proposed system captures images of printed text through the ESP32-CAM module and transmits them wirelessly to a Python-based processing system using Wi-Fi communication. OCR technology is used to extract textual information from the captured image, while a TTS engine converts the extracted text into speech output for user understanding. The system is designed to be lightweight, low-cost, portable, and easy to use. Experimental results demonstrate that the proposed model performs effectively under suitable lighting conditions and successfully converts printed text into understandable speech. The system can be applied in educational institutions, libraries, offices, and smart assistive environments. Future enhancements include multilingual support, voice command integration, offline OCR processing, and AI-based technologies for improved functionality.*

Keywords: ESP32-CAM, Optical Character Recognition (OCR), Text-to-Speech (TTS), Blind Assistance System, Assistive Technology, Artificial Intelligence

I. INTRODUCTION

Visually impaired people often experience difficulties in reading printed materials such as books, newspapers, notices, and official documents. In most situations, blind individuals depend on family members, teachers, or assistants to read textual information, which limits their independence and accessibility. With advancements in embedded systems, image processing, and artificial intelligence, smart assistive devices can provide better support for visually impaired individuals.

The Smart Hearing Aid for Blind Device (SHABD) is an innovative system designed to help visually impaired individuals access printed information independently. The proposed system uses an ESP32-CAM module to capture images of printed text. The captured image is transmitted wirelessly through Wi-Fi to a Python-based processing system, where Optical Character Recognition (OCR) extracts the text content. After text extraction, a Text-to-Speech (TTS) engine converts the recognized text into voice output, allowing users to hear the content through speakers or earphones.

The proposed system aims to provide an affordable and portable reading assistant for blind individuals. Compared to traditional assistive technologies, the system offers wireless communication, easy operation, and cost-effectiveness. The major objective of this project is to reduce dependency and improve accessibility for visually impaired users in educational, professional, and daily life activities[1-180].



II. LITERATURE REVIEW

Literature Review 1: FingerReader – A Wearable Device to Support Text Reading on the Go (Shilkrot et al., 2014)
Shilkrot et al. developed the FingerReader, a wearable device designed for visually impaired users to read printed text independently. The system used a small camera, OCR, and Text-to-Speech (TTS) technology to convert printed text into audio output. It also provided haptic feedback for line tracking. Although the system demonstrated effective real-time text reading, limitations such as lighting dependency and external processing requirements reduced portability.

Literature Review 2: Maes_FingerReader – A Wearable Device (MIT Media Lab, 2014)
Maes and her team improved the FingerReader system by enhancing portability and text-reading accuracy. The system used OCR and TTS technologies with improved finger tracking and faster response time. However, challenges related to battery life, processing dependency, and device size still remained.

Literature Review 3: Wearable Assistive System for the Visually Impaired (ResearchGate, 2020)
This research proposed a camera-based OCR and TTS system for visually impaired users. The system focused on real-time text recognition and speech conversion without depending completely on external devices. However, performance was affected by poor lighting and motion instability, highlighting the need for better adaptability.

Literature Review 4: Real-Time Text-to-Speech Conversion System (IEEE Xplore, 2021)
This study introduced a Raspberry Pi-based text-to-speech system for blind users using a camera module, OCR, and speech synthesis. The system provided better portability and processing speed but still faced limitations related to internet dependency and text recognition accuracy.

Summary of Literature Review

From the literature survey, it is observed that existing systems suffer from limitations such as high cost, internet dependency, limited portability, and reduced accuracy under poor lighting conditions. Therefore, the proposed Smart Hearing Aid for Blind Device (SHABD) aims to provide an affordable, portable, and efficient text-reading assistance system using ESP32-CAM, OCR, and Text-to-Speech technology

III. PROBLEM STATEMENT

Visually impaired individuals face major difficulties in accessing printed information independently. Most blind users depend on other people for reading books, documents, newspapers, and educational materials. Existing assistive systems are often expensive, less portable, and difficult to operate. Therefore, there is a need for a low-cost, portable, and smart reading system that can convert printed text into speech and help blind individuals access information independently.

IV. OBJECTIVES OF THE PROJECT

The main objective of the proposed Smart Hearing Aid for Blind Device (SHABD) is to develop an affordable, portable, and efficient assistive device that helps visually impaired individuals read printed text independently through audio output. The project aims to utilize ESP32-CAM, OCR technology, and Text-to-Speech conversion to improve accessibility and reduce dependency on others for reading printed materials.

The specific objectives of the project are as follows:

1. To capture images of printed text using the ESP32-CAM module.
2. To establish wireless communication between the ESP32-CAM and the Python processing system using WiFi technology.
3. To extract textual information from captured images using Optical Character Recognition (OCR) technology.
4. To convert the extracted text into audible speech using a Text-to-Speech (TTS) engine.



5. To provide real-time reading assistance for visually impaired users.
6. To design a low-cost and portable smart reading system that can be easily used in daily life.
7. To improve accessibility and independence for blind individuals in educational and public environments.
8. To reduce hardware complexity and implementation cost using embedded system technology.
9. To ensure easy operation and user-friendly interaction for visually impaired users.
10. To create a flexible system architecture that supports future enhancements such as offline OCR, multilingual support, AI integration, and voice command features.

V. PURPOSE OF THE SYSTEM

The primary purpose of the proposed Smart Hearing Aid for Blind Device (SHABD) system is to help visually impaired individuals read printed text independently without relying on other people. The system captures text images using an ESP32-CAM module and converts the extracted text into speech output. The proposed solution aims to improve accessibility, independence, and learning opportunities for blind individuals. Additionally, the system focuses on affordability, portability, and ease of operation for daily use.

VI. SYSTEM ARCHITECTURE

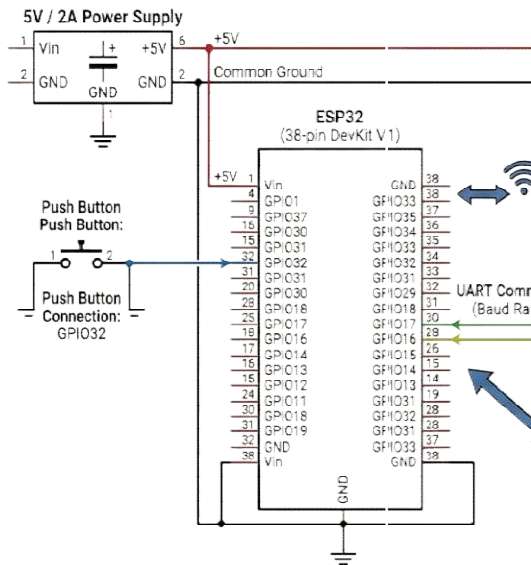

Fig. 1. Proposed System Circuit Diagram

VII. HARDWARE REQUIREMENTS

The following hardware components are used in the proposed system:

1. ESP32-CAM Module – Used for image capturing and wireless communication.
2. ESP32 Development Board – Used for uploading program code.
3. USB Cable – Used for power and programming.
4. Speaker / Earphones – Used to provide voice output.
5. Adjustable Stand – Helps in stable camera positioning.
6. Power Supply / Power Bank – Provides required power to the system.



VIII. SOFTWARE REQUIREMENTS

The following software tools are required for implementation:

1. **Arduino IDE** – Used for programming ESP32-CAM.
2. **Python 3.x** – Used for image processing and OCR operations.
3. **OCR.Space API** – Used for text extraction from images.
4. **OpenCV Library** – Used for image enhancement and preprocessing.
5. **pyttsx3 Library** – Used for text-to-speech conversion.
6. **ESP32 Board Package** – Required for ESP32 configuration.

IX. WORKING PRINCIPLE

The working principle of the proposed system involves image capturing, text extraction, and speech generation. Initially, the ESP32-CAM captures the image of printed text. The image is then transferred through Wi-Fi to the Python system. OCR technology processes the captured image and extracts readable text. The extracted text is converted into speech using the pyttsx3 text-to-speech engine. Finally, the generated voice output is played through speakers or earphones, allowing the visually impaired user to hear the printed information.

X. METHODOLOGY

The methodology of the proposed system consists of several modules working together to provide text-to-speech assistance.

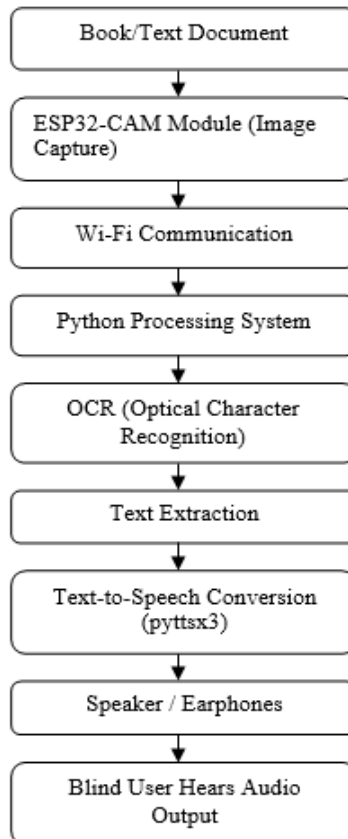

Fig. 2. Proposed System Workflow



The ESP32-CAM captures images of printed text and transfers them wirelessly to a Python-based system through Wi-Fi. OCR technology extracts readable text from the image, and a text-to-speech engine converts it into understandable audio output for the user.

XI. ADVANTAGES AND LIMITATIONS

Advantages

1. Low-cost assistive solution.
2. Portable and easy to carry.
3. Wireless communication using Wi-Fi.
4. Provides real-time speech output.
5. Improves independence of visually impaired users.
6. Easy to use and user-friendly.

Limitations

1. OCR accuracy depends on proper lighting conditions.
2. Internet connection is required for OCR API functionality.
3. Blurry images may reduce recognition accuracy.
4. Difficulty in recognizing handwritten text.

XII. APPLICATIONS

The proposed system can be applied in the following areas:

1. Reading printed books and newspapers.
2. Educational support for blind students.
3. Reading office and government documents.
4. Smart assistive technology for visually impaired individuals.
5. Personal reading assistant for daily life activities.

XIII. FUTURE ENHANCEMENT

The proposed system can be improved in the future by incorporating advanced technologies. Offline OCR functionality can be added to remove internet dependency. Voice command support can improve usability. Artificial Intelligence-based text recognition can increase accuracy. Multi-language support can help users understand content in different languages. Mobile application integration can make the system more portable and efficient.

XIV. RESULTS AND DISCUSSION

The proposed system was successfully implemented and tested for printed text recognition. The ESP32-CAM effectively captured images and transferred them wirelessly to the Python processing system. OCR technology successfully extracted readable text from captured images, and the pyttsx3 engine converted the text into understandable speech output. Experimental results demonstrated that the system performs efficiently under proper lighting conditions and provides useful assistance for visually impaired users.

XV. CONCLUSION

The Smart Hearing Aid for Blind Device (SHABD) is an effective assistive technology developed for visually impaired individuals. The proposed system successfully combines ESP32-CAM, OCR, Wi-Fi communication, and text-to-speech technologies to convert printed text into voice output. The system is affordable, portable, and easy to use, making it highly beneficial for blind users. The proposed solution reduces dependency on others and enhances accessibility to printed information.



ACKNOWLEDGMENT

We express our sincere gratitude to Prof. E. R. Chandane, Department of Electronics and Telecommunication Engineering, Shree Siddheshwar Women's College of Engineering, Solapur, for valuable guidance and continuous support throughout this project work. We also thank Dr. S. C. Mhamane, Head of Department, for encouragement and providing necessary facilities for successful completion of this research work. Finally, we thank our institution and team members for their cooperation and support.

REFERENCES

1. R. Shilkrot, J. Huber, C. Liu, P. Maes, and S. C. Nanayakkara, "FingerReader – A Wearable Device to Support Text Reading on the Go," Proceedings of the 32nd Annual ACM Conference on Human Factors in Computing Systems (CHI), 2014.
2. MIT Media Lab, "Finger-Mounted Reading Device for the Blind," MIT News, 2014.
3. P. Maes, R. Shilkrot, and S. Nanayakkara, "Maes_FingerReader – A Wearable Device for Text Reading by the Visually Impaired," MIT Media Lab Technical Report, 2014.
4. S. C. Nanayakkara, R. Shilkrot, and P. Maes, "Wearable Assistive Devices for the Blind," IEEE Transactions on Human-Machine Systems, vol. 45, pp. 589–600, 2015.
5. P. S. Dandekar and A. R. Khandekar, "Smart Wearable Assistive System for Visually Impaired People," International Journal of Innovative Research in Computer and Communication Engineering, vol. 4, no. 3, 2016.
6. R. P. Jain, S. A. Patil, and K. A. More, "Assistive Text Reading Using Optical Character Recognition and Text-to-Speech," Procedia Computer Science, vol. 85, pp. 268–275, 2016.
7. N. Patel, A. Sharma, and M. Bhagat, "Smart Vision System for the Blind Using Raspberry Pi," International Journal of Advanced Research in Computer and Communication Engineering, vol. 6, no. 5, 2017.
8. V. K. Reddy and S. Rajasekhar, "Design and Implementation of Voice-Assisted Device for the Visually Impaired," International Journal of Engineering Research & Technology (IJERT), vol. 8, no. 9, 2019.
9. R. M. Rani, G. Kumar, and A. J. Francis, "A Smart Stick for the Blind Using Ultrasonic Sensors and Voice Feedback," IEEE International Conference on Communication and Signal Processing (ICCSP), 2020.
10. Z. Chen, X. Liu, M. Kojima, Q. Huang, and T. Arai, "A Wearable Navigation Device for Visually Impaired People Based on Real-Time Semantic Visual SLAM System," Sensors, vol. 21, no. 4, 2021.
11. S. C. Sethuraman, G. R. Tadkapally, S. Mohanty, G. Galada, and A. Subramanian, "MagicEye: An Intelligent Wearable Towards Independent Living of Visually Impaired," arXiv Preprint, 2023.
12. J. Ramadhan et al., "Wearable Smart System for Visually Impaired People," Sensors, vol. 18, no. 3, 2018.
13. Ashit Gaikwad, Amogsidha Chendke, Nizam Mulani, and Mangrule Sarika, "Submersible Pump Theft Indicator", IEJRD - International Multidisciplinary Journal, vol. 5, no. 4, p. 5, May 2020. Available at: <https://www.iejrd.com/index.php/%20/article/view/627>
14. Kazi Kutubuddin Sayyad Liyakat Saheb, Significance of rotation and projection of image in Child Healthcare System', Gradiva Review Journal, Volume 3 Issue 1 2017, pp. 51-55. Available at: <https://gradivareview.net/wp-content/uploads/2026/06/9.GRJ8948.pdf>
15. Mr. Akhilesh Raut, Mr. Mahesh Mali, Miss. Trupti Mashale, Prof. Kazi K. S. (2018). Bagasse Level Monitoring System, International Journal of Trend in Scientific Research and Development (ijtsrd), Volume-2, Issue-3, April 2018, pp.1657-1659, URL: <https://www.ijtsrd.com/papers/ijtsrd11469.pdf>
16. N. R. Mulla and K. K. S. Liyakat, (2025). Pipeline Pressure and Flow Rate Monitoring Using IoT Sensors and ML Algorithms to Detect Leakages, Int. J. Artif. Intell. Mech. Eng., vol. 1, no. 1, pp. 20–30, Jun. 2025.
17. Nikat Rajak Mulla, (2025). Sensor-based Aircraft Wings Design Using Airflow Analysis, International Journal of Image Processing and Smart Sensors, vol. 1, no. 1, pp. 55-65, Jun. 2025.



18. N. R. Mulla and K. K. S. Liyakat, (2025). A Study on Machine Learning for Metal Processing: A New Future, *International Journal of Machine Design and Technology*, vol. 1, no. 1, pp. 56–69, Jun. 2025.
19. N. R. Mulla, and K. K. S. Liyakat, “Node MCU and IoT Centered Smart Logistics,” *International Journal of Emerging IoT Technologies in Smart Electronics and Communication*, vol. 1, no. 1, pp. 20-36, Jun-2025.
20. Renuka Dnyanoba Todakar, Jadhav Vaibhavi Kishor. (2025). Kinetic Power Gyms for Revolutionizing Fitness. *Journal of Telecommunication, Switching Systems and Networks*. 2025; 12(02):13-21. Available from: <https://journals.stmjournals.com/jotssn/article=2025/view=214971>
21. Kazi Kutubuddin Sayyad Liyakat. Cardiovascular Modeling with Computational and Mathematical Methods. *Research & Reviews: A Journal of Bioinformatics*. 2025; 12(2): 1–11p.
22. Nikat Rajak Mulla, Kazi Kutubuddin Sayyad Liyakat. Air Flow Analysis in Sensor-Based Aircraft Wings Design. *Recent Trends in Fluid Mechanics*. 2025; 12(2): 29– 39p.
23. Nikat Rajak Mulla, Kazi Kutubuddin Sayyad Liyakat. IoT Sensors To Monitor Pipeline Pressure and Flow Rate Combined with MI-Algorithms to Detect Leakages. *Recent Trends in Fluid Mechanics*. 2025; 12(2): 40– 48p.
24. Heena Rafiq Shaik, Kazi Kutubuddin Sayyad Liyakat. Juncture of Nanotechnology and IoT: Novel Era of Connectivity. *Nano Trends – A Journal of Nano Technology & Its Applications*. 2025; 27(03):- . Available from: <https://journals.stmjournals.com/nts/article=2025/view=212921>
25. Kazi Kutubuddin Sayyad Liyakat. Machine Learning Revolutionizing Server Management and Performance. *Journal of Computer Technology & Applications*. 2025; 16(02):- . Available from: <https://journals.stmjournals.com/jocta/article=2025/view=0>
26. Kazi Kutubuddin Sayyad Liyakat. KVS Approach for IoT Network Security: A Novel Approach to IoT Network Security With B-Cell Inspired Models. *Journal of Network security*. 2025; 13(02):16-25. Available from: <https://journals.stmjournals.com/jons/article=2025/view=207920>
27. Dr. Kazi Kutubuddin Sayyad Liyakat. Nanotechnology: Effective Pesticide Solutions for Jawar Leaf Diseases. *Journal of Nanoscience, NanoEngineering & Applications*. 2025; 15(02):- . Available from: <https://journals.stmjournals.com/jonsnea/article=2025/view=204242>
28. Parkhe Suyash Swaminath, Dhyavarkonda Udaykiran Tulshidas, Todkar Renuka Dnyanoba, Pawar Radhika Maruti, Kazi Kutubuddin Sayyad Liyakat. Nanotechnology in Internet of Things: A Powerful Partnership Shaping the Future. *Journal of Nanoscience, NanoEngineering & Applications*. 2025; 15(02):- . Available from: <https://journals.stmjournals.com/jonsnea/article=2025/view=211534>
29. Nikat Rajak Mulla, Kazi Kutubuddin Sayyad Liyakat. Nano-Materials in Vaccine Formation and Chemical Formulae’s for Vaccination. *Journal of Nanoscience, NanoEngineering & Applications*. 2025; 15(03):- . Available from: <https://journals.stmjournals.com/jonsnea/article=2025/view=216526>
30. A. K. Mulani, H. T. Shaikh, and K. K. S. Liyakat, (2025). Nuclear Power Generation Using UO2 Materials, *Journal of Advance Electrical Engineering and Devices*, Vol. 3, No. 2, pp. 27-40, Jul. 2025.
31. H. T. Shaikh and K. K. S. Liyakat, “Empowering the IoT: The Study on Role of Wireless Charging Technologies,” *Journal of Control and Instrumentation Engineering*, vol. 11, no. 2, pp. 29-39, Jul. 2025.
32. H. T. Shaikh, and K. K. S. Liyakat, “Pre-Detection Systems Transfiguring Intoxication and Smoking Using Sensor and AI,” *Journal of Instrumentation and Innovation Sciences*, vol. 10, no. 2, pp. 19-31, Jul. 2025.
33. Vaishnavi Ashok Desai, (2025). AI and Sensor Systems Revolutionizing Intoxication and Smoking Pre-Detection. *Journal of Control & Instrumentation*. 2025; 16(3): 15–26p.
34. Heena Tajoddin Shaikh. (2025). The Future of Coastal Resilience: Harnessing Satellite Technology. *Advance Research in Communication Engineering and Its Innovations*, 28–36. Retrieved from <https://matjournals.net/engineering/index.php/ARCEI/article/view/2281>
35. H. T. Shaikh and K. K. S. Liyakat., (2025). Sensor- based Intelligent Wearable Glasses, *Journal of Digital Circuitry Innovations in Electrical Devices*, vol. 1, no. 2, pp. 16-24, Jul. 2025.



36. Kazi Kutubuddin Sayyad Liyakat. Nanorobots: The Fight against Cholesterol. Nano Trends – A Journal of Nano Technology & Its Applications. 2025; 27(02). Available from: <https://journals.stmjournals.com/nts/article=2025/view=205244>
37. H. T. Shaikh and K. K. S. Liyakat, “Millimetre Wave: A Study on the Backbone of Future IoT Connectivity”, Advance Research in Analog and Digital Communications, Vol. 2, no. 2, pp. 20-31, Aug. 2025.
38. Ayesha Khalil Mulani. Microwave Signals: A New Frontier in Non-Invasive Medical Diagnostics: A Study. Journal of Microwave Engineering & Technologies. 2025; 12(3): 27–41p.
39. Ayesha Khalil Mulani. Revolutionizing Optical Fibre Field Distribution with Linear Finite Element Method. Trends in Opto-electro & Optical Communication. 2025; 15(3): 31-41p.
40. H. T. Shaikh and K. K. S. Liyakat, (2025). Robust Access Control Mechanisms in IoT Security using VHDL Programming, Journal of VLSI Design and Signal Processing, vol. 11, no. 2, pp. 31-40, Aug. 2025. Available at: <https://matjournals.net/engineering/index.php/JOVDSP/article/view/2351>
41. Radhika Maruti Pawar, Kulkarni Amarja Bhaskar, Patu Shradha Gangadhar, Sensors and Artificial Intelligence based Intelligent Thermos. Recent Trends in Sensor Research & Technology. 2025; 12(3): 37–45p.
42. Ayesha Khalil Mulani. Optical Fibre Pressure Sensor in Medicine: A Study. Recent Trends in Sensor Research & Technology. 2025; 12(3): 18–27p.
43. Vaishnavi Ashok Desai, Heena Tajoddin Shaikh, Sensor and AI Based Pre- Detection Systems Transfiguring Intoxication & Smoking. Journal of Telecommunication, Switching Systems and Networks. 2025; 12(3): 37–50p.
44. C. M. Abhangrao and K. K. S. Liyakat, “A study on hybrid intelligence in COBOT,” Journal of Mechanical Robotics, vol. 10, no. 2, pp. 15–29, Sep. 2025.
45. Heena Tajoddin Shaikh, (2025). The Future of Cancer Management: A Guide to Nanosensor Applications. Recent Trends in Semiconductor and Sensor Technology, 1–10.
46. Heena T Shaikh. A Study on Automatic Feedback Control by Image Processing for Mixing Solutions in a Microfluidic Device. International Journal of Advanced Control and System Engineering. 2025; 3(2): 32–41p.
47. Heena T Shaikh. A Study on Unmanned Air Vehicles (UAV). Journal of Aerospace Engineering & Technology. 2025; 15(3): 14–27p.
48. K. K. S. Liyakat, “Waste-to-Energy (WtE) Plants: A Study,” Journal of Alternative and Renewable Energy Sources, vol. 11, no. 3, pp. 1-15, Oct. 2025.
49. Sultanabanu Sayyad Liyakat. (2024). Advancing IoT Connectivity through Very Large-Scale Integration of Semiconductor Technology. Journal of Semiconductor Devices and Circuits. 2024; 11(03):54-63. Available at: <https://journals.stmjournals.com/josdc/article=2024/view=190467/>
50. Dr. Kazi Kutubuddin Sayyad Liyakat. Sensor and IoT centered Smart Agriculture by NodeMCU. Recent Trends in Sensor Research & Technology. 2024; 11(03): 24-32. Available from: <https://journals.stmjournals.com/rtsrt/article=2024/view=0>
51. Dr. Kazi Kutubuddin Sayyad Liyakat. KSK Approach to Smart Agriculture: Utilizing AI-Driven Internet of Things (AI IoT). Journal of Microcontroller Engineering and Applications. 2024; 11(03): 41-50. Available from: <https://journals.stmjournals.com/jomea/article=2024/view=0>
52. Pathan Muskan Ibrahim.(2025). Photochemical Materials for Light-Responsive Optical Switching: AI-Optimized Design of Dynamic Visual Effects. International Journal of Photochemistry and Photochemical Research, Volume 3, Issue 2. 2025; 3(2): 13–27p.
53. Shaikh A. Hakim A. Razzaque. (2025). A Study on AI-Enhanced Environmental Toxicology: Sensor-Driven Predictive Framework. Research & Reviews: A Journal of Toxicology. 2025; 15(3): 1–20p.



54. Paul Pranit Sunil, Dhyvarkonda Udaykiran Tulshidas, Gone Yashasvi Prakash. (2025). AI-Powered Motorcycle Anti-Theft and Safety System, *International Journal of Advanced Research in Science, Communication and Technology*, Volume 5, Issue 1, October 2025. pp. 445- 454.
55. P. M. Ibrahim and K. K. S. Liyakat, "Guardian Angel: An Innovative Mobile Application for Rapid Accident Notification and Emergency Response," *Advance Research in Analog and Digital Communications*, vol. 2, no. 3, pp. 7-20, Oct. 2025.
56. Muskan Ibrahim, Shaikh A. Hakim A. Razzaque, Heena T Shaikh, Kazi. (2025). VHDL-Based Strategies for Protecting IoT Devices from Power and Electromagnetic Side-Channel Attacks: A Study. *Recent Trends in Electronics & Communication Systems*. 2025; 12(3): 30–40p. Available at: <https://journals.stmjournals.com/article/article=2025/view=234151/>
57. Amar Parmeshwar Bansode, (2025). Electronics and Communication Design of an AI-Powered Smart Chair for Real-Time Multilingual Interaction. *Recent Trends in Electronics & Communication Systems*. 2025; 12(3): 16–29p.
58. Pathan Muskan Ibrahim, Shaikh A. Hakim A. Razzaque, Heena T Shaikh, Kazi Kutubuddin Sayyad Liyakat. (2025). Reimagining Nuclear Reactor Safety: The Study toward Passive Safety. *Journal of Nuclear Engineering & Technology*. 2025; 15(3): 6–15p.
59. Ayesha Khalil Mulani, Heena Tajuddin Shaikh. (2025). Nuclear Reactor Safety Using Fuel Pallet: A Study. *Journal of Nuclear Engineering & Technology*. 2025; 15(3): 16–23p.
60. Sunil Mishra and Liyakat, (2025). Sensors in Metallurgy Applications: A Study, *Journal of Recent Activities in Production*, vol. 10, no. 2, pp. 11-22, Oct. 2025. Available at: <https://matjournals.net/engineering/index.php/JoRAP/article/view/2576>
61. Muskan Pathan. (2025). Study of Agriculture Using Drones in India: Evaluation of Feasibility, Impact, and Adoption Challenges. *International Journal on Drones*. 2025; 1(2): 21–33p. Available at: <https://journals.stmjournals.com/ijd/article=2025/view=230379/>
62. Kazi Kutubuddin Sayyad Liyakat. (2025). A Study on Recent Trends in Chemical Sensors for Detecting Toxic Materials. *Journal of Modern Chemistry & Chemical Technology*. 2025; 16(3): 25–34p. Available at: <https://journals.stmjournals.com/jomcct/article=2025/view=234528/>
63. Heena T Shaikh. (2025). E-Commerce Study Using AR/VR and Ethical Convergence of Commerce. *E-Commerce for Future & Trends*. 2025; 12(3): 20–26p. Available at: <https://journals.stmjournals.com/ecft/article=2025/view=232592/>
64. Nikat Rajak Mulla, Bhakti Haridas Gavali, Ayesha Khalil Mulani, Vaibhavi Kishor Jadhav, (2025). Nanotechnology: Revolutionizing the World of Sensors. *International Journal of Applied Nanotechnology*. 2025; 11(2): 1–9p. Available at: <https://journalspub.com/publication/ijan/article=21245/>
65. Liyakat, (2025). Revolutionizing Petrology and Mineralogy: The Study of AI and Advanced Sensor Technologies. *International Journal of Mineral*. 2025; 2(2): 1–11p. Available at: <https://journals.stmjournals.com/ijmi/article=2025/view=232613/>
66. Sayyad & Liyakat (2025). AR Coatings in Solar Efficiency: A Study. *Journal of Thin Films, Coating Science Technology and Application*. 2025; 12(3): 25–34p. Available at: <https://journals.stmjournals.com/article/article=2025/view=235156/>
67. Sanika Anil Bhosale, (2025). AI-Based Software-Defined Satellite in Decision Making: A Study. *International Journal of Satellite Remote Sensing*. 2025; 03(01):63-72. Available from: <https://journals.stmjournals.com/ijrsr/article=2025/view=207998>.
68. Heena T. Shaikh. (2025). A Study on Insect Journey Using Sensor. *International Journal of Insects*. 2025; 2(2): 1–7p. Available at: <https://journals.stmjournals.com/article/article=2025/view=234932/>



69. Bhagyarekha Ujjwalganesh Dhaware, (2025). A Smart Stove System for Cooking Food: A Study. International Journal of Electrical Machine Analysis and Design. 2025; 3(2): 1–10p. Available at: <https://journals.stmjournals.com/article/article=2025/view=235595/>
70. Milind Shivaji Kadam, (2025). Power of Optical Sensors in Remote Sensing: A Study. International Journal of Satellite Remote Sensing, 2025; 3(2): 29–36p. Available at: <https://journals.stmjournals.com/article/article=2025/view=235438/>
71. IR. (2025). A Study of Optical Sensor in Clinical applications. International Journal of Optical Innovations & Research. 2025; 3(2): 1–7p. Available at: <https://journals.stmjournals.com/article/article=2025/view=235439/>
72. Muskan Pathan, (2026). Exploring the Intersection of Blockchain and Cybersecurity. Current Trends in Information Technology. 2026; 16(1): 32–42p.
73. Shaikh Heena T, Kazi Kutubuddin Sayyad Liyakat. (2025). Satellite Sensing in Aero-Plan Guidance and Radar Tracking System. International Journal of Satellite Remote Sensing. 2025; 3(2): 1–9p. Available at: <https://journals.stmjournals.com/issue/ijwsn-volume-03-Issue-02-2025/>
74. K. K. S. Liyakat, (2025). AI-driven Convergent Channel Allocation for 7G Mobile Networks: A Study, Journal of RF and Microwave Communication Technologies, vol. 2, no. 3, pp. 19-30, Dec. 2025. Available at: <https://matjournals.net/engineering/index.php/JoRFMCT/article/view/2825>
75. Ayesha Khalil Mulani, Kazi Kutubuddin Sayyad Liyakat. (2025). Transforming IoT with mmWave: A Study. International Journal of Microwave Engineering and Technology. 2025; 11(2): 1–9p.
76. Nikat R. Mulla, Kazi Kutubuddin Sayyad Liyakat. (2025). Predictive Maintenance of 6G Infrastructure Using Artificial Intelligence. International Journal of Telecommunication and Emerging Technologies. 2025; 11(2): 1–10p. Available at:
77. Heena T Shaikh, Kazi Kutubuddin Sayyad Liyakat. (2025). Symmetry Principles in Digital Twin Systems: Modeling, Integration, and Applications. Emerging Trends in Symmetry. 01(02):06-24p. Available from: <https://journals.stmjournals.com/etsy/article=2025/view=233711>
78. Kazi Kutubuddin Sayyad Liyakat. (2025). Cloud Computing-Based Software Testing. International Journal of Software Computing and Testing. 11(2): 17–25p.
79. Mayur Saudagar Jadhav, and Kazi Kutubuddin Sayyad Liyakat. (2025). Smart Cameras Integrated With Artificial Intelligence (AI) and Human Pose Estimation: A Study. International Journal of AI and Machine Learning Innovations in Electronics and Communication Technology, 1(2): 1–12. Accessed December 13, 2025. <https://matjournals.net/engineering/index.php/IJAIMLECT/article/view/2424>.
80. Nikat Rajak Mulla. (2025). A Transformative Approach to Empathetic Climate Change by Satellite Sensing. Research & Reviews : Journal of Space Science & Technology. 2025; 14(03):35-42. Available from: <https://journals.stmjournals.com/rjssst/article=2025/view=228204>
81. Kazi Kutubuddin Sayyad Liyakat, Efficiency Improvements in Long-Distance Wireless Power Transmission. International Journal of Electrical Power System and Technology. 2024; 10(01): -p. Available from: <https://journalspub.com/publication/ijepst/article=11880>
82. Mulla Nikat, Kazi Kutubuddin. Securing IoT Wilderness with VHDL. International Journal of VLSI Circuit Design & Technology. 2025; 03(01):29-40. Available from: <https://journals.stmjournals.com/ijvcdt/article=2025/view=206696>
83. Nikat Rajak Mulla, Kazi Kutubuddin Sayyad Liyakat. GSM Based Intelligent Homes. International Journal of Electrical and Communication Engineering Technology. 2025; 03(02):- . Available from: <https://journals.stmjournals.com/ijecet/article=2025/view=229260>
84. Kazi Kutubuddin Sayyad Liyakat. (2022). Text Analysis in Health Care Study Using IoT, Journal of Computer Technology & Applications, Vol 13, No 3. Available at: <https://computerjournals.stmjournals.in/index.php/JoCTA/article/view/955>.



85. Kazi Kutubuddin Sayyad Liyakat. Enhancing LAN Security Using Machine Learning. International Journal of Wireless Security and Networks. 2025; 03(02):07-16. Available from: <https://journals.stmjournals.com/ijwsn/article=2025/view=232814>
86. Kazi Kutubuddin Sayyad Liyakat. (2024). Smart Agriculture based on AI-Driven-IoT (AIIoT): A KSK Approach. Advance Research in Communication Engineering and Its Innovations, 23–32. Retrieved from <https://matjournals.net/engineering/index.php/ARCEI/article/view/746>
87. Heena Tajoddin Shaikh. (2025). A Study on Innovations in Primary Containment Technology for Safer Nuclear Power. Journal of Nuclear Engineering & Technology. 2025; 15(03):- . Available from: <https://journals.stmjournals.com/jonet/article=2025/view=233190>
88. Kazi Kutubuddin Sayyad Liyakat. (2025) Tiny Titans: The Promise of E-Nanorobots in the Fight against Cancer. Journal of Advancements in Robotics. 2025; 12(02):11-21. Available from: <https://journals.stmjournals.com/joar/article=2025/view=0>
89. Nikat Rajak Mulla. (2025) Analysis of Field Distribution in Optical Fibre Using FEM Method. Trends in Opto-electro & Optical Communication. 2025; 15(02):31-40. Available from: <https://journals.stmjournals.com/toec/article=2025/view=215300>
90. Nikat Rajak Mulla. (2025). Internet of Things Connectivity Using Millimetre Wave: A Study. Journal of Microwave Engineering and Technologies. 2025; 12(02):18-30. Available from: <https://journals.stmjournals.com/jomet/article=2025/view=215480>
91. Kazi Kutubuddin Sayyad Liyakat. (2025). Fog Computing Architecture and Deployment in IoT. International Journal of Distributed Computing and Technology. 2025; 11(2): 1–9p.
92. Heena T. Shaikh, Kazi Kutubuddin Sayyad Liyakat. (2025). Improved Programming Model Using AI: Shifting from Imperative Coding to Declarative Intent. International Journal of Software Computing and Testing. 11(2): 1–9p. Available at: <https://journalspub.com/publication/ijsc/article=22151/>
93. Heena Kazi. (2025) Collaborative Approaches in Using Satellite Data for Climate Action: A study. International Journal of Atmosphere. 2(2): 1–9p. Available at: <https://journals.stmjournals.com/article/article=2025/view=234886/>
94. Shaikh Heena T, Kazi Kutubuddin Sayyad Liyakat. (2025). The Versatility of the IC 741 in Electronic Sensor System Design. International Journal of Analog Integrated Circuits. 2025; 11(2): 8–13p. Available at: <https://journalspub.com/publication/ijaic/article=23144/>
95. Kazi Kutubuddin Sayyad Liyakat. (2025) Navigating the Antenna Frontier for Emerging IoT Technologies. International Journal of VLSI Circuit Design & Technology. 2025; 3(2): 1–10p. Available at: <https://journals.stmjournals.com/ijvcdt/article=2025/view=235614>
96. K. K. S. Liyakat, (2025). A Study on Side-Channel Attack Countermeasures in IoT Security using VHDL Programming, Journal of VLSI Design and Signal Processing, vol. 11, no. 3, pp. 27-36, Dec. 2025. Available at: <https://matjournals.net/engineering/index.php/JOVDSP/article/view/2897>
97. Kazi Kutubuddin Sayyad Liyakat. (2025). Hybrid Intelligence (HI) in Cyber Security: A Study. International Journal of Wireless Security and Networks. 2026; 4(1): 1–9p.
98. Kazi Kutubuddin Sayyad Liyakat, Heena T. Shaikh, Kazi Sultanabanu Sayyad Liyakat. (2025). Cloud Security Using Machine Learning: A Study. International Journal of Distributed Computing and Technology. 2025; 11(2): 1–10p. Available at: <https://journalspub.com/publication/ijdct/article=22139>
99. H. T. Shaikh, and K. K. S. Liyakat, (2025). The Future of Radar Antenna Design: A Study, Advance Research in Communication Engineering and its Innovations, vol. 2, no. 3, pp. 18-28, Dec. 2025. Available at: <https://matjournals.net/engineering/index.php/ARCEI/article/view/2913>
100. Heena T. Shaikh, Kazi Kutubuddin Sayyad Liyakat. (2025). 4 x 4 Multi-Band MIMO Antenna: A Study. International Journal of Microwave Engineering & Technology. 2025; 11(2): 1–11p.



101. Heena T. Shaikh, Pathan M. Ibrahim, Kazi K. S. Liyakat. (2025). A Study on the Future of Industrial Wastewater Treatment Plant: Trends and Innovations. *International Journal of Chemical Engineering and Processing*. 2025; 11(2): 1–13p. Available at: <https://journalspub.com/publication/ijocep/article=22386/>
102. Kazi Kutubuddin Sayyad Liyakat, Heena T. Shaikh. (2025). e-Kidney Filtration System (EKS) Using Sensor: A Study. *International Journal of Chemical Separation Technology*. 2025; 11(2): 1–10p.
103. Kazi Kutubuddin Sayyad Liyakat. (2025). Building a Secure IoT Ecosystem with TRNGs and VHDL. *Journal of Telecommunication and Emerging Technologies*. 2025; 11(2): 1–8p.
104. Milind Shivaji Kadam, Vaishnavi Gopal Shirsikar, N. N. Shaikh, Aditi Dinanath Shahane, Kazi Kutubuddin Sayyad Liyakat. (2025). A Study in Leveraging Deep Learning and IoT Arrays for Dynamic, Hyper-Local Atmospheric Intelligence. *International Journal of Atmosphere*. 2025; 2(2): 50–62p. Available at: <https://journals.stmjournals.com/article/article=2025/view=234909/>
105. Shaikh Heena Tajoddin, Ir. Kazi Kutubuddin Sayyad Liyakat. (2025). Carbon-Based Supercapacitors Evolutionizing EVs. *Journal of Materials & Metallurgical Engineering*. 2025; 15(3): 66–76p. Available at: <https://journals.stmjournals.com/article/article=2025/view=235071/>
106. Kazi Kutubuddin Sayyad Liyakat. (2025). Epidemiology and Transmission of Infectious Diseases Study Using Machine Learning. *International Journal of Pathogens*. 2025; 2(2): 10–20p. Available at: <https://journals.stmjournals.com/article/article=2025/view=234948/>
107. Sultanabanu, Shaikh Heena T. (2025). A Study on IoT and AI for Predictive Modeling and Control of Infectious Disease Transmission. *International Journal of Pathogens*. 2025; 2(2): 1–9p. Available at: <https://journals.stmjournals.com/article/article=2025/view=234953/>
108. K. Kazi, Sayyad Liyakat, (2025). VHDL Programming for Secure Bootloaders in IoT Security. *International Journal of VLSI Circuit Design & Technology*. 2025; 03(01):19-28. Available from: <https://journals.stmjournals.com/ijvcdt/article=2025/view=206693>
109. Jadhav Vaibhavi Kishor. (2025). Robust Access Control Mechanisms Using VHDL Programming for IoT Security. *Journal of VLSI Design Tools and Technology*. 2025; 15(02):6-19. Available from: <https://journals.stmjournals.com/jovdtt/article=2025/view=224414>
110. Heena T Shaikh and Dr. Kazi Kutubuddin Sayyad Liyakat, Innovating IoT Security: VHDL as a Solution for Bootloader Vulnerabilities. *International Journal of Microelectronics and Digital integrated circuits*. 2025; 11(02): -p. Available from: <https://journalspub.com/publication/ijmdic/article=23170/>
111. Heena T Shaikh, IR. Kazi Kutubuddin Sayyad Liyakat. (2026). Multi-Layered AI-Driven Security in Wireless Ecosystems. *International Journal of Wireless Security and Networks*. 2026; 4(1): 21–28p.
112. Dr. Kazi Kutubuddin Sayyad Liyakat. Integrated, Geospatial Risk Assessment of Air, Water, and Soil Pollution Impacts on Agricultural Sustainability using Advanced Digital Technologies. *International Journal of Environmental Noise and Pollution Control*. 2025; 03(02):28-37. Available from: <https://journals.stmjournals.com/ijenpc/article=2025/view=230868>
113. IR. Dr. Kazi Kutubuddin Sayyad Liyakat, Heena T Shaikh. Study on Antibiotic Resistance: An Analysis of Molecular Mechanisms and Therapeutic Implications. *International Journal of Antibiotics*. 2026; 3(1): 9-21p.
114. V. Maske, S. Pauskar, V. Gundagi, S. H. T, and K. K. S. Liyakat, “Two-Way Tracking System for Buses Augmented by Intelligent Sensor and VLSI Technology: A Study,” *Journal of VLSI Design and Signal Processing*, vol. 12, no. 1, pp. 14-27, Jan. 2026. Available at: <https://matjournals.net/engineering/index.php/JOVDSP/article/view/3038>
115. Kazi Kutubuddin Sayyad Liyakat. Study on Accelerating Threat of Emerging Infectious Diseases (EIDs) and Imperative for a Proactive, Interdisciplinary Global Health Security Framework. *International Journal of Tropical Medicines*. 2026; 3(1): 9–22p.
116. Heena T. Shaikh, Kazi Kutubuddin Sayyad Liyakat. (2026). A Study on Precision Blood Propulsion in Motor-Driven Artificial Hearts. *Trends in Electrical Engineering*. 2026; 16(1): 51–57p.



117. Kazi Kutubuddin Sayyad Liyakat, Heena T Shaikh. (2026). Multi-Layered AI-Driven Paradigm Shift in IoT Ecosystem Security. *Journal of Communication Engineering & Systems*. 2026; 16(1): 13–21p.
118. Heena T. Shaikh, Kazi Kutubuddin Sayyad Liyakat. Analysis of Machine Learning in Metal Processing: A Novel Prospect. *Journal of Materials & Metallurgical Engineering*. 2026; 16(1): 40–51p.
119. H. T. Shaikh and K. K. S. Liyakat, “A Study into Accurate Blood Pumping in Motor-powered Artificial Hearts,” *Advance Research in Power Electronics and Devices*, vol. 3, no. 1, pp. 1-9, Feb. 2026.
120. Kazi Kutubuddin Sayyad Liyakat. A Technical Survey on Nanotechnology in Nanorobots. *Journal of Nanoscience, Nanoengineering & Applications*. 2026; 16(1): 14–21p. Available at: <https://journals.stmjournals.com/article/article=2026/view=239242/>
121. Vaishnavi Gopal Shirsikar, Aditi Dinanath Shahane, Kazi Kutubuddin Sayyad Liyakat. A Study on Securing the Local Area Network with the Immutable Trust of Blockchain. *International Journal of Distributed Computing and Technology*. 2026; 12(1): 23–33p.
122. Heena T. Shaikh, (2026). A Study on Controlling Artificial Heart. *Journal of Control & Instrumentation*. 2026; 17(1): 14–23p.
123. H. T. Shaikh, and K. K. S. Liyakat, –A Study on AI-powered Ultra-low Latency in 6G: A Blueprint for the Next-Generation Mobile Communication System || , *Advance Research in Communication Engineering and its Innovations*, vol. 3, no. 1, pp. 29-41, Mar. 2026.
124. Dhyvarkonda Udaykiran Tulshidas, Pranit Sunil Paul, Gone Yashasvi Prakash, IR. Kazi Kutubuddin Sayyad Liyakat. Revolutionizing School Schedules: An Arduino-Based Automatic Class Bell System with Real-Time Precision. *Journal of Control & Instrumentation*. 2025; 16(02):35-44. Available from: <https://journals.stmjournals.com/joci/article=2025/view=213292>
125. Kazi Kutubuddin Sayyad Liyakat. (2026). T-Flip-Flop Implementation using Quantum-dot Cellular Automata. *Journal of Electronics Design and Technology*, 24–32. Retrieved from <https://matjournals.net/engineering/index.php/JEDT/article/view/3282>
126. Heena T. Shaikh, Kazi Kutubuddin Sayyad Liyakat. Thin Film Technology in Sensor Manufacturing – A Technical Discussion. *Journal of Thin Films, Coating Science Technology and Application*. 2026; 13(1): 48–58p.
127. Heena T Shaikh, Dr. Kazi Kutubuddin Sayyad Liyakat. A study on CMOS Operational Amplifier in Sensor Development. *Journal of VLSI Design Tools and Technology*. 2026; 16(01):- . Available from: <https://journals.stmjournals.com/jovdtt/article=2026/view=238929>
128. Heena T. Shaikh, IR. Kazi Kutubuddin Sayyad Liyakat. An Overview on Energy Harvesting Using Piezoelectric Material for Wi-Fi Systems. *International Journal of Electro-Mechanics and Material Behavior*. 2026; 4(1): 56– 63p.
129. K. K. S. Liyakat, T-Flip-Flop Implementation using Quantum-dot Cellular Automata || , *Journal of Electronics Design and Technology*, vol. 3, no. 1, pp. 24-32, Mar. 2026.
130. H. T. Shaikh and K. K. S. Liyakat, “An Overview of Transforming IoT with Millimeter-Wave,” *Journal of RF and Microwave Communication Technologies*, vol. 3, no. 1, pp. 18-28, Mar. 2026. Available at: <https://www.matjournals.net/engineering/index.php/JoRFMCT/article/view/3327>
131. Kutubuddin Sayyad Liyakat Kazi, (2025). Roll of AI and Sensor in Aerospace: A Study, *Journal of Advance Research in Aeronautics and Space Science*, Vol. 12 No. 3&4. Available at: <https://adrjournalshouse.com/index.php/Jof-aeronautics-space-science/article/view/2589>
132. Heena T. Shaikh, Kazi Kutubuddin Sayyad Liyakat. The Future of Farming with IoT-Operated Drones. *International Journal on Drones*. 2026; 2(1): 20–26p. Available at: <https://journals.stmjournals.com/article/article=2026/view=239864/>
133. Kazi Kutubuddin Sayyad Liyakat. An Overview on Quantum dot Technology in Temperature Sensor Design. *Journal of Electronic Design Technology*. 2026; 17(1): 10–17p.



134. Shaikh Heena T, Kazi Kutubuddin Sayyad Liyakat. Sensors-Based Electric Machine Design for Industry. International Journal of Electrical Machine Analysis and Design. 2026; 4(1): 1-10p. Available at: <https://journals.stmjournals.com/article/article=2026/view=240174/>
135. Heena T Shaikh, Kazi Kutubuddin Sayyad Liyakat. An Overview on Intelligent Operating Systems (iOS). Journal of Operating Systems Development & Trends. 2026; 13(1): 21–28p. Available at: <https://journals.stmjournals.com/article/article=2026/view=242357/>
136. Kazi Kutubuddin Sayyad Liyakat, A Study of Self-Healing Polymer Nanocomposites with Filler Effect. International Journal of Applied Nanotechnology. 2026; 12(1): 26-35p. Available from: <https://journalspub.com/publication/uncategorized/article=24828>
137. H.T. Shaikh, and K. K. S. Liyakat, —A Study on AI-driven Security Concerns in the Wireless Ecosystem, Research & Review: Electronics and Communication Engineering, vol. 3, no. 1, pp. 27-38, Apr. 2026.
138. Heena T. Shaikh, Kazi Kutubuddin Sayyad Liyakat. Optimization of Pesticide Requirement Calculations for IoT- Operated Hexacopter Delivery Systems. International Journal on Drones. 2026; 2(1): 8–14p. Available at: <https://journals.stmjournals.com/ijd/article=2026/view=239857/>
139. Heena T. Shaikh, & Kazi Kutubuddin Sayyad Liyakat. (2026). A Study on AI-driven Security Concerns in the Wireless Ecosystem. Research & Review: Electronics and Communication Engineering, 27–38. Retrieved from <https://matjournals.net/engineering/index.php/RRECE/article/view/3446>
140. Kazi Kutubuddin Sayyad Liyakat. Nano-Chemical Revolution in Vaccinology: A Study. Research & Reviews: A Journal of Immunology. 2026; 16(1): 26–38p.
141. Chopade Mallikarjun Abhangrao¹, IR. Kazi Kutubuddin Sayyad Liyakat. KSK Approach: An AI-Driven IoT Based Decision Making System’s Study. Current Trends in Signal Processing. 2025; 15(02):14-25. Available from: <https://journals.stmjournals.com/ctsp/article=2025/view=215216>
142. Heena T Shaikh and Kazi Kutubuddin Sayyad Liyakat, An investigation into the use of nanotechnology in medical-military applications. International journal of Nanobiotechnology. 2026; 12(1): -p. Available from: <https://journalspub.com/publication/uncategorized/article=25271>
143. Kazi Kutubuddin Sayyad Liyakat, An Overview on Nanomaterial-Enabled Electronic Skin for Physiological Sensing and Biomedical Use. International journal of Nanobiotechnology. 2026; 12(1): -p. Available from: <https://journalspub.com/publication/uncategorized/article=25280>
144. Heena T. Shaikh, Kazi Kutubuddin Sayyad Liyakat. A Technical Overview of Nanorobots Using Nanotechnology. International Journal of Nanomaterials and Nanostructures. 2026; 12(1): 31–38p. Available from: <https://journalspub.com/publication/uncategorized/article=25222>
145. Heena T. Shaikh, Kazi Kutubuddin Sayyad Liyakat. A Survey on Hydrogen Storage System using Alloys. International Journal of Energetic Materials. 2026; 12(1): 13–19p.
146. Kazi Kutubuddin Sayyad Liyakat. Intelligent Trajectories: Harnessing Artificial Intelligence for Next Generation Missile and Propellant Design. International Journal of Energetic Materials. 2026; 12(1): 20–26p.
147. Kazi Kutubuddin Sayyad Liyakat. A Review of Electrical Conduction, Optical Sensing, and Semiconductor Device Innovations. Journal of Semiconductor Devices and Circuits. 2026; 13(1): 10–18p.
148. Kazi Kutubuddin Sayyad Liyakat, Heena T Shaikh. Dual-Wavelength and Tunable Fiber Lasers for Microwave Photonic Applications. Journal of Microwave Engineering & Technologies. 2026; 13(1): 17–25p.
149. Heena Shaikh, Kazi Kutubuddin Sayyad Liyakat. Electromagnetic Field Effects on Biological Systems and Safety Evaluation of Microwave Exposure. Journal of Microwave Engineering & Technologies. 2026; 13(1): 26–33p.
150. Kazi Kutubuddin Sayyad Liyakat, Heena T Shaikh. An Overview on Microwave Remote Sensing for Earth Observation. Research & Reviews: Journal of Space Science & Technology. 2026; 15(1): 21–25p.



151. Kazi Kutubuddin Sayyad Liyakat, Heena T Shaikh. An Overview on Harnessing Microwave Frequencies for Next-Generation Satellite Communication and Earth Observation. *Research & Reviews: Journal of Space Science & Technology*. 2026; 15(1): 1–6p.
152. Kazi Kutubuddin Sayyad Liyakat. AI-Driven IoT in Self-Healing Grid Power Systems: A Study. *International Journal of Electrical Power System and Technology*. 2026; 12(1): 15–24p.
153. Kazi Kutubuddin Sayyad Liyakat, Heena T Shaikh. An Overview on Microwave Remote Sensing for Earth Observation. *Research & Reviews: Journal of Space Science & Technology*. 2026; 15(1): 21–25p.
154. Liyakat K S S, Heena T S, Liyakat K K S. A study on Cognitive Signal Processing for Terahertz Horizons: The Role of AI in Enabling 7G Communication Networks. *J Adv Res Sig Proc App* 2025; 7(2): 8-12.
155. Liyakat K K S. Design and Optimisation of a Robust D-Flip Flop in Quantum-dot Cellular Automata Technology using QCA Designer. *J Adv Res Microelec VLSI* 2025; 8(2): 14-24.
156. Sayyad Liyakat. AI Driven IoT Based Satellite Remote Sensing System: KSK Approach in Satellite Remote Sensing. *International Journal of Satellite Remote Sensing*. 2026; 4(1): 50–57p.
157. Sayyad Liyakat, Heena T Shaikh. Nuclear Reactor Safety Using Seismic and Natural Disaster Protection: A Study. *Journal of Nuclear Engineering & Technology*. 2026; 16(1): 25–34p.
158. Heena T Shaikh. Photonic Diagnostics: Harnessing Optical Sensing for Non-Invasive Assessment of Coronary Obstruction. *International Journal of Optical Innovations & Research*. 2026; 4(2): 25–30p.
159. Heena T Shaikh, Kazi Kutubuddin Sayyad Liyakat. A Comprehensive Review of CMOS Analog Circuit Design Techniques for Low-Power VLSI Systems. *International Journal of VLSI Circuit Design & Technology*. 2026; 4(1): 12–24p.
160. Kazi Kutubuddin Sayyad Liyakat. Performance Improvement of Standalone Solar PV Pumping System Using Supercapacitor. *International Journal of Electrical Power and Machine Systems*. 2026; 4(1): 62–70p.
161. Heena Shaikh, Kazi Kutubuddin Sayyad Liyakat. Enhancing Solar Water Pumping in arid Regions with Hybrid Super Capacitor and Battery Storage. *International Journal of Electrical Power and Machine Systems*. 2026; 4(1): 18–29p.
162. S. H. Tajoddin, P. S. Kolhe, and K. K. S. Liyakat, “An Overview of Microcontroller-based Intelligent Pill Box Employing Sensors by E-mail Facility,” *Journal of Electronics Design and Technology*, vol. 3, no. 2, pp. 13-23, May 2026.
163. Kazi Kutubuddin Sayyad Liyakat. An AI-Driven IoT Framework for Autonomous Quality Assurance in Optical Lens Manufacturing. *International Journal of Optical Innovations & Research*. 2026; 4(1): 36–41p.
164. Kazi Kutubuddin Sayyad Liyakat. A Study on the Use of AI and Sensors in Aerospace. *Journal of Aerospace Engineering & Technology*. 2026; 16(1): 24–33p.
165. Kazi Kutubuddin Sayyad Liyakat, Heena T. Shaikh. An Overview of Reimagining MOSFET as Precision Thermal Sensor. *International Journal of Analog Integrated Circuits*. 2026; 12(1): 8–13p.
166. Kazi Kutubuddin Sayyad Liyakat, Heena Shaikh, Kosgiker G.M. An Overview on VLSI based Hardware Security in IoT Node. *International Journal of VLSI Circuit Design & Technology*. 2026; 4(1): 51–56p.
167. Heena T Shaikh, Kazi Kutubuddin Sayyad Liyakat. Intelligent Electromagnetic Synthesis: An AI-Driven IoT Framework for Adaptive Antenna Design in Missile Navigation. *International Journal of Radio Frequency Innovations*. 2026; 4(1): 1–15p.
168. Heena T Shaikh, Kazi Kutubuddin Sayyad Liyakat. A Study on AI-Driven Multi-Layered Defense in 6G Ecosystems. *International Journal of Radio Frequency Innovations*. 2026; 4(1): 1–9p.
169. Liyakat K K S. A Study on Intelligent Missile Launching, IoT based Sight and Shoot Capability, *Journal of Advanced Research in Aeronautics and Space Science*, 2026; 13(1&2): 20-25. Available at: <https://adrjournalshouse.com/index.php/Jof-aeronautics-space-science/article/view/2729>

