

Power Quality Improvement of PV Integrated System Using Unified Power Quality Conditioner

Ms. Laxmi Laxminarayan Jakkan

In-charge Head, Electrical Department

S. E. S. Polytechnic, Solapur, India

jakkan.laxmi@gmail.com

Abstract: *The advance use of power electronic devices introduces harmonics in the supply system which creates a problem in the quality of power delivered. Good Power Quality is very much important for our day today use of appliances in both industrial and domestic sectors. So to improve power quality of a system, we use different devices such as ACTIVE POWER FILTERS (APF). Active power filters are classified into two types that is Shunt Active Power Filter (APF) and Series Active Power Filter (APF) and combination of both is known as UPQC (Unified Power Quality Conditioner). Here we have done simulation of Shunt Active Power Filter, Series Active Power Filter and Unified Power Quality Conditioner. Shunt APF is used to mitigate the problems due to current harmonics which is because of non-linear load and make source current sinusoidal and distortion free. The control scheme used is hysteresis current controller using “p-q0 theory”.*

The prime focus of this project is to implementation the control of instantaneous power (p-q) for the operation of Unified Power Quality Conditioner (UPQC) which is one of the recent technology that includes both series and shunt active power filter operating at the same time and thereby improves all the current and voltage related problem like voltage sag/swell, flicker, etc. at the same time and helps in reduction of Harmonic Distortion.

In this paper, it is shown via MATLAB simulation how UPQC model can be used on PV integrated distribution system to decrease the distortion in source voltage, source current and load voltage waveforms created due to non-linear/ sensitive loads usage.

Keywords: Power quality

I. INTRODUCTION

Power quality is an essential problem in distribution system. Quality of power is sincerely described as the voltage quality i.e. the purity of the transferred power. According to IEEE Std.1100 power quality is described by the concept of powering and grounding sensitive systems in a way that it is appropriate for the exceptional operation of that equipment. However, the power quality is disturbed or destroyed due to numerous issues occur in the power system e.g. ‘voltage sag’, ‘Voltage swell’, ‘unbalance of voltage and current’, ‘harmonics produced in voltage and current flickers’, ‘Transient over-voltage’, ‘supply interruption’, and many others. The permissible ‘supply voltage’ and ‘load current distortion’ (THD) restrict as per IEEE standards should be maintained. Harmonic present in current components create numerous troubles such as:

- Growth of loose cable in power device,
- Failures in rotating equipment due to insulation failure and overheating,
- Failures of transformers, conductor, and cables due to insulation failure and overheating,
- Burden of reactive power,
- Low efficiency of machine,
- Bad power factor issue,
- Excessiveness of neutral currents and unbalances of electrical system,
- Protective relay small function and premature tripping



Above addressed issues associated with power quality are reduced with the help of filters. There are 2 kinds of filters 'passive filter' and an 'active filter'. An Active power filter is greater popular than passive ones due to their tiny size, speedy outcome, and better regulation. The Active power filter (APF) has mitigate the issue related with current, voltage, and improvement of power factor. Now a day's power generation and distribution machine is turning especially vulnerable to the exclusive power quality issue said above.

The full-size use of nonlinear masses/loads is furtherleads to elevated troubles of current and voltage harmonics. Moreover, the injection level of short/big-scale renewable energy systems based on solar energy, gas cells, Wind energy, etc. Its installations at transmission and distribution networks are growing drastically. This consolidation of generation in a power system is producing new demanding situations to the electric energy enterprise to accommodate those systems. For distribution systems, UPQC is the deal with those issues and obtained the solution for mitigating strength quality problems.

Here we analyzed solar PV included with electrical Grid distribution system with UPQC and as compared with PV incorporated without UPQC approach system.

1.1 SOLAR PHOTOVOLTAIC ENERGY

A photovoltaic machine is a tool that uses one or more solar panels to convert solar power into strength. It includes more than one component, such as the photovoltaic modules, mechanical and electrical connections, mountings, and ways of regulating and/or enhancing the electrical output.

PV cells are manufactured from semiconductor substances, at the side of Si (silicon). For PV cells, a thin wafer semiconductor is particularly treated to form an electric field, one side is positive and other side is negative. While slight power hits the solar cell, electrons are free to knocked from the atoms within the material semiconductor. If conductors are connected to the high satisfactory and terrible sides, and form an electrical circuit, the electrons may be gathered in the form of an electric-powered current. This energy then used as a load electricity.

For general use the produced power is not enough by a single PV cell. So for high voltage requirement connect many single PV cell in series and for high current requirement connected in parallel to get the desired power. Generally Module said a series connection, commercial modules consist of 36 or 72 cells. The unnecessary adequate reverse current characteristics produced by mono-crystalline silicon cells p-n junctions. This currents discard the power and can leads shaded cells overheated.

At higher temperatures, Solar cells become less efficient so good ventilation behind solar panels must be required.

The combination of many PV cells in series or parallel interconnection of modules made a photovoltaic array (PV system). For commercial use, the produced power is not enough which is extracted by a single module, so array are formed by the number of modules to supply the load. Inverters are used to convert PV arrays DC power into AC that can supply the power to AC loads. In the modules of PV array to obtain the desired voltage panels are firstly connected in series and to allow the system to supply more current then individual modules are connected in parallel manner.

Wind and solar are Renewable power sources which have a low environmental impact and ampere sources. As a consequence, they're now extensively used within the distribution systems for increase the generation. Solar panel especially is extensively used when we consider that it is able to be used for all types of power generation programs and additionally for specific power grades. The consolidation of green energy with power quality development technology which includes number of FACTS devices such as dynamic voltage restorer(DVR), UPQC, and DSTATCOM which gives the advantages of generation of energy along with PQ improvement. The proposed power flow diagram of the PV-UPQC is proven below; it consists of array of PV panel added with UPQC with a boost converter. This converter work on maximum power point tracking (MPPT) mode for extraction of peak power from the PV array. The UPQC have a Series and Shunt Converter compensator linked to a common DC-bus. The circuit incorporates 3phase power that is providing an on linear load.



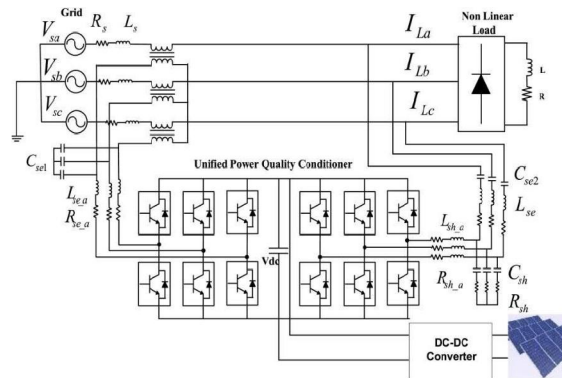

II. POWER QUALITY IMPROVEMENT TECHNIQUES

For a variety of reasons, power quality has become a major problem. Some of the most important causes are as follows:

- Increase the efficiency of the power system for many new tools such as shunt capacitors and adjustable-speed motor drives. These devices increase the harmonic level of the energy system to increase anxiety.
- For effective power supplies and loads, the usage of microprocessor-based controls and microcontrollers are strongly suffering from power quality problems.
- Related networks used nowadays are badly affected by power system disruption because if any element fails the whole machine is affected.
- Awareness of problems in the power quality and the difficulties faced such as low voltage, overvoltage, flicker, etc. it is either the service customers or end-users who are growing significantly which raises the need for higher quality and better power.

2.1 METHODS OF POWER QUALITY IMPROVEMENT

Flexible AC transmission systems (FACTS) controllers were in particular used for solving various steady-state control issues in power system. FACTS devices allow the flexible and dynamic control of electricity structures. Three groups the FACTS devices can be divided dependent on their switching generation: Mechanical Switching (together with phase moving transformers), Switched by Thyristor or speedy switched, and Switched by IGBTs

Different statistics controllers are as follows:

SVC: Static VAR Compensator

Static VAR Compensator (SVC) is the first technology facts device that can manipulate voltage at the desired bus thereby enhancing the voltage profile of the machine. For several purposes Static VAR systems are implemented by using utilities in transmission applications.

The primary reason is generally for speedy control of voltage at vulnerable points in a network.

TCSC: Thyristor Controlled Series Capacitor

TCSC is one of the critical device of the FACTS family, via the utilities in modern power systems. This is an increasing number of applied with long transmission lines.

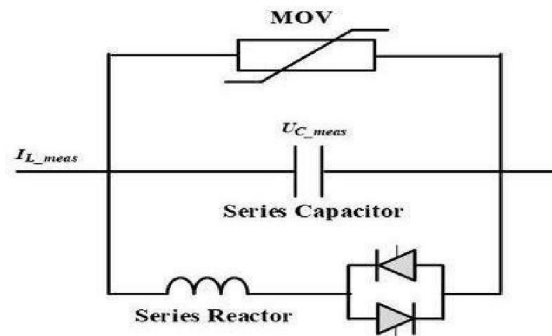

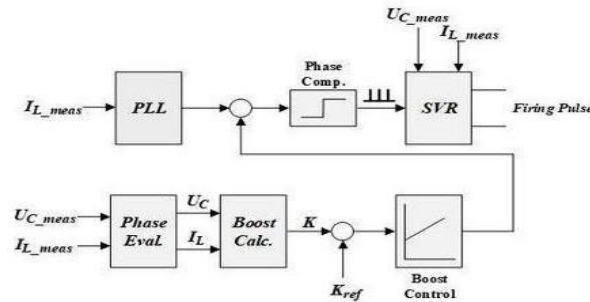

SSSC: Static Synchronous Series Compensator

A SSSC is a device of FACTS family which is connected with a power system in series manner. It have solid state voltage source converter, generates a controllable AC voltage at fundamental frequency.

UPFC: Unified Power Flow Controller

The UPFC supply and absorb both real and reactive power and it having ‘AC/DC converters’. One converters is attached with the transmitting line in series manner and the second is connected with shunt transformer in parallel manner.

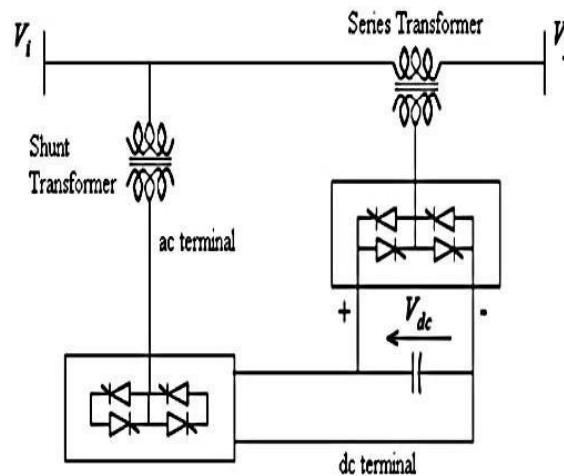

UPQC: Unified Power Quality Conditioner

For many of the available facts devices, the Unified Power Flow Controller (UPFC) is the maximum versatile device that may be used to enhance transient stabilitydynamic stability and steady-state stability.



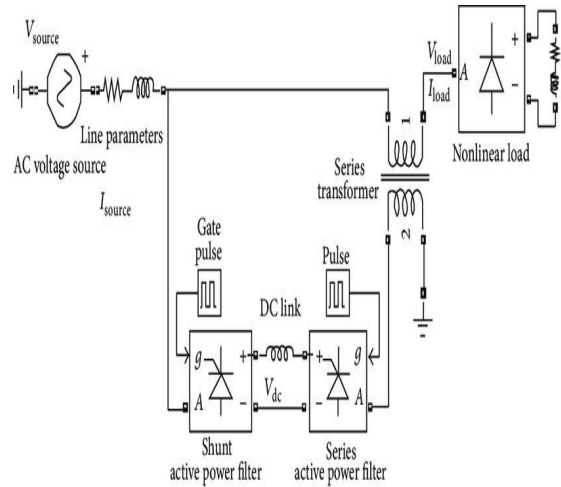

III. INTRODUCTION TO UNIFIED POWER QUALITY CONDITIONER

INTRODUCTION

The main part of UPQC are series APF, shunt APF. The series APF is very promising to minimize electrical PQ-related distortions and the shunt APF is best suited to compensate for current PQ-related distortions. In the modern distribution system, both voltage and current related PQ distortions simultaneously deteriorate the performance of the load. However, installing series APF and shunt APF independently may not be effective solutions and also it is not suitable for simultaneous compensation of voltage and current PQ distortions. It introduced a new topology in which series APF and shunt APF were connected back to back with a common DC link reactor and the topology was named as line voltage regulator/conditioner (LVRC).

The UPQC was constructed from two voltage source inverters, DC link capacitor, three single-phase coupling transformers and interfacing impedances. One voltage source inverter (VSI) was connected in series with the source through coupling transformers via series interfacing impedance. This was named as series VSI. Another VSI was connected in parallel between the coupling transformer and load impedance through shunt interfacing impedance known as shunt VSI.

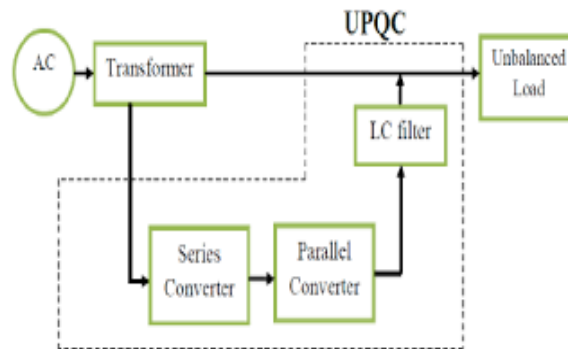

3.2 FUNCTIONS PERFORMED BY UPQC

The control method of UPQC performs a completely critical function in supply system. The UPQC control approach follows 3 steps.

To hear electric signals using a 'Power transformer' and current signals with the use of a 'Current transformer'.

Derive compensating signal in terms of voltage and current standards. Fast and efficient power (p-q principle), in addition to the 'Synchronous reference framework method' (d-q concept), is the extensively helpful method for controlling the time domain in order to gain compensation.



Generate the gating signals for semiconductor switches of UPQC by using hysteresis, PWM, or fuzzy logic based controlling techniques.

IV. UPQC SYSTEM MODELING

4.1 CONFIGURATION OF UPQC

Shunt APF:

A VSC i.e. voltage-source inverter attached to equal AC supply line and acts as a current source to take away current interference, reduce current-based load performance, and enhance load ability. It additionally has capabilities as a DC-link voltage controller, reducing the DC capacitor voltage. The current impact of the shunt converter can be controlled using the usage of a dynamic hysteresis band (DHB) based on controlling the semiconductor function so the current output follows the reference signal and stays within the expected hysteresis band (PHB).

Fundamental Structure of Shunt APF

The fundamental structure of the shunt APF consists of:-

DC capacitor - It is an electrical energy storage component that enables the actual power variation between the source and the load at regular intervals.

Power source converter - VSI, like IGBT and GTO, is a robust device. It is used to activate current compensating energy in to the current load, so that harmonics in load current mitigated and the source current remains untouched. In addition, the current drawn from the AC source is completely sinusoidal. VSI provides a PWM signal for operation.

Current Hysteresis Controller - To operate the VSC, the current Hysteresis controller generates a PWM signal. An error generated by comparing the actual current and the reference current which used as a PWM signal.

Steps to control the shunt APF

Production of reference current compensation

Production of an input signal with a current hysteresis controller

Series APF:

To compensate voltage disruptions, a voltage-supply inverter connected in series with the AC supply line and acts as a line voltage source. It is used to reduce the voltage fluctuations from the voltage supply and fed to the load end through series transformer. The inverter's output voltage has managed by the usage of series pulse-width modulation (SPWM). The gate pulses for the inverter are generated by using comparing the fundamental and reference voltages to the excessive-frequency triangular waveform.

The fundamental structure of series APF

The APF series has the following basic components

Series Transformer

DC Voltage regulator

Power source inverter

Hysteresis Voltage Controller

Steps to control series APF

Generation of reference compensating voltage.

Comparing reference compensating voltage with actual compensating voltage in hysteresis voltage controller and generating PWM signal for voltage source inverter.

4.2 SIMULINK MODELS OF PV-INTEGRATED SYSTEM

In a transmission system, independent control of the actual power and operating power is essential to maintain the desired voltage level in the transmission system. In this project the two bus system considered and simulated with the help of Simulink blocks. The UPQC is connected to this system to achieve dependent free control of reactive and real power.

The actual power is controlled independently by changing the voltage injection angle of the UPQC and the operating power is controlled by changing the magnitude of the shunt voltage injected by the UPQC. Harmonic distortion occur in the system due to nonlinear load and is measured by a single value such as Total Harmonic Distortion (THD).Volts



and currents have parts of frequency that are not the absolute frequency, then the supply system is called inter harmonics supply system. It can be found in networks of all levels of electricity. The sources of distortion of the inter harmonics wave shape are power circuits such as vertical frequency converters, cyclo converters, induction furnaces, and arcing instruments.

The inverter output contains unusual harmonics, causes the failure or misuse of consumer goods. PWM is considered when the lower order harmonics are eliminated and the higher-order harmonics are harmless because their magnitude is ignored. THD is a measurement of voltage harmonic at the base voltage.

4.3 CIRCUIT MODEL OF PV-INTEGRATED SYSTEM WITH UPQC

The UPQC is one of the FACTS devices which includes D-STATCOM and DVR. D-STATCOM is connected with distribution line in shunt manner. The main function is to introduce there active power via controller into the main supply. It's far viable to attain UNITY POWERFACTOR in the supply if the D-STATCOM boost whole reactive power and power losses. With the use of the control algorithms, we acquire the right monitoring (injected current is similar the reference current) and THD reduced from source current. So that within the control strategy, reference current generation is generated. In series manner DVR is connected with the load and mitigate sag/swell voltage. UPQC is a set of DVR and DSTATCOM, used to improve the power quality of the machine.

In the circuit diagram of 3-phase UPQC, PLL and Hysteresis controller technique are used. The source is modeled as 400V, 3 phase system, and is taken into consideration as the grid of Distribution system.

The voltage of DC link is 365 V that is the output voltage of an integrated PV machine. At the Point of common coupling, the controller of parallel connected D- STATCOM is specifically supposed to introduced reactive power to the grid. Unity power factor may be occurred if no imaginary current is extract from the source. The reference current has to be derived by fetching the source to deliver real power and losses only. To mitigate the voltage sag and swells the DVR is used in the network. For peak power extraction this converter work on 'MAXIMUM POWER POINT TRACKING' (MPPT) mode from the array of solar panel.

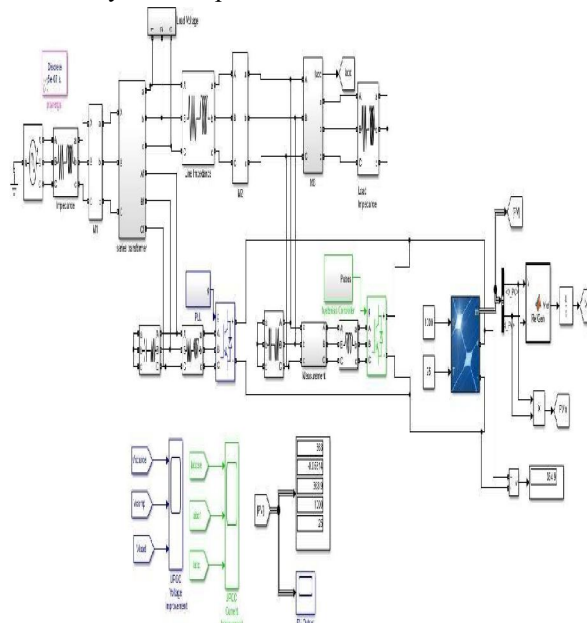

4.4 CONFIGURATION OF PV-INTEGRAED WITH UTILITY GRID

The overall block diagram of the proposed PV integrated distribution system with UPQC is shown in Fig. 4.8. For peak power extraction from the PV-array, this system having converter which works on maximum power point tracking (MPPT) mode. The UPQC includes a Series and Shunt compensator related to a common DC-bus. A detailed circuit diagram of the PV integrated with UPQC device is shown in Fig. 4.5. The circuit contains of 3phase voltage which is



providing to a nonlinear load. A UPQC device includes two back-to-back PLL and Hysteresis controllerbased converters linked through a solar PV array.

This array is connected to the UPQC-Grid system through coupling transformers across the DC link.

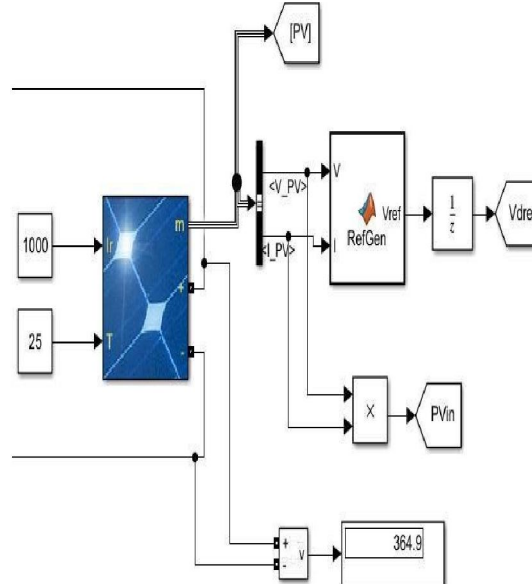

V. SIMULATION RESULT

5.1 SIMULATION RESULTS OF PV-INTEGRATED SYSTEM WITH UPQC SIMULATION RESULTS OF SERIES APF

The sag duration stages from 0.02to0.04 seconds. The noise and vibration are caused by an electrical imbalance fault. Because of those fault supply voltage magnitude drops to147.5V from 312, that's relative affects the user end appliances and the inflation ranging from 0.06 sec to 0.1sec. at some stage in this time, voltage swells up to 502V from 312V which may additionally bethe cause of overheating hassle at the consumer end. Voltage swelling might be caused by faults or adjustments within the capacitor.

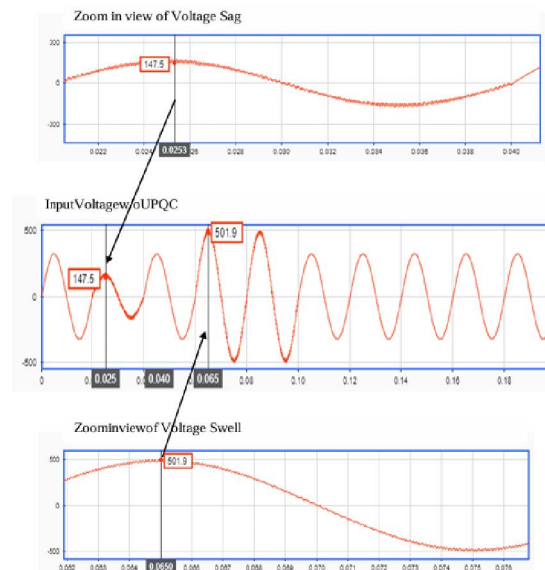

Compensation voltage is injected from the Series converter over a period of time from 0.02 sec to 0.04 sec and 0.06 sec to 0.1 seconds, via injecting this voltage, the load voltage throughout series APF becomes absolutely regulated.



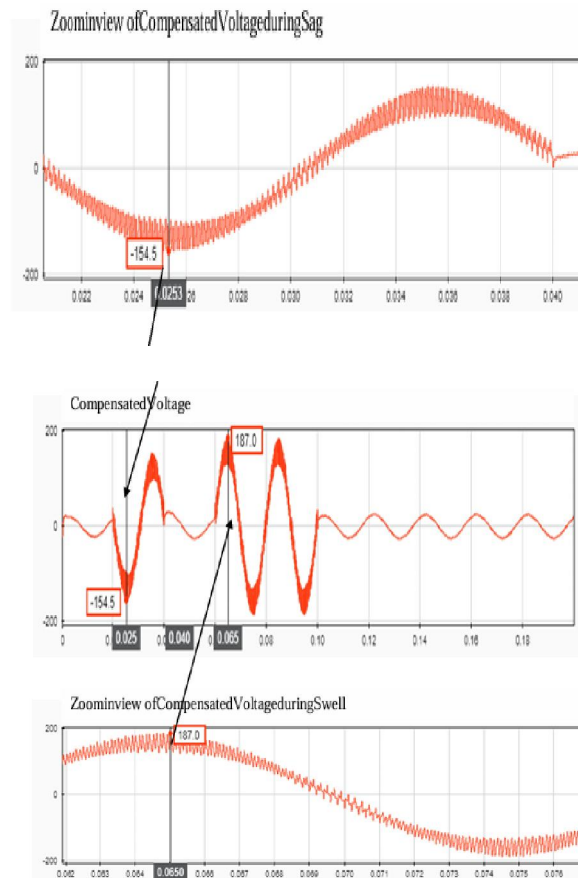

Now the load voltage of the series APF is sinusoidal and balanced. After the utility of the series APF, the load voltage is identical. The sag at the time of 0.02 to 0.04 seconds is removed and the voltage rises from a length of 0.06 seconds to 0.1 seconds removed with the help of the series APF. The loading voltage is free from all imbalances. Now the voltage is flawlessly equal all through the complete time.

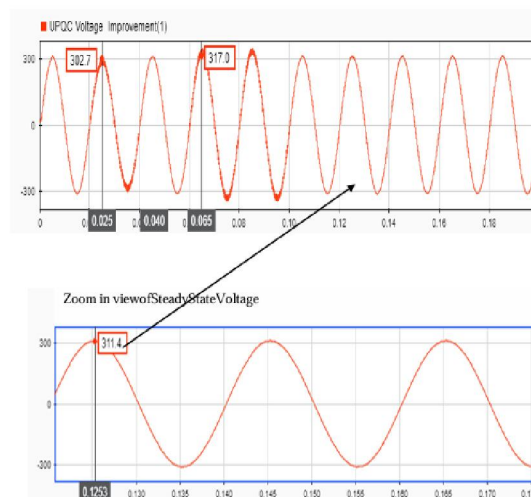

SIMULATION RESULTS OF SHUNT APF

The Injected current waveform is supplied and is not sinusoidal because of the presence of indirect loads. They have non-linear because of the presence of indirect masses along with diodes and so on.



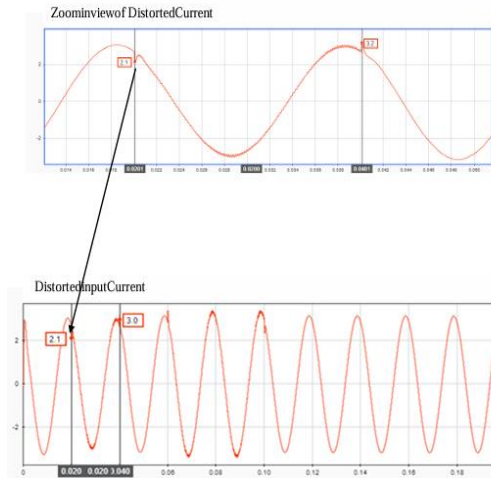

Since the shunt APF is currently not operational, the current source contains harmonics up to 0.01 seconds. The shunt APF begins operating on the system after 0.01 seconds. As a result, the harmonics were removed from the current source after 0.01 seconds. A circuit breaker regulates the operating time of the shunt APF.

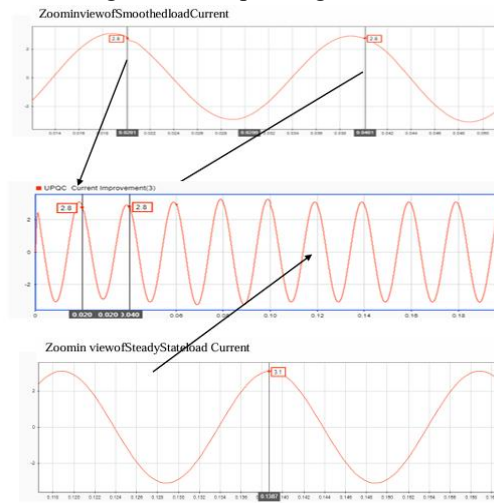

VI. CONCLUSION

The integrated quality conditioner was researched and investigated in this project to improve Power quality. UPQC is a type of universal filter, simulated with the help of MATLAB software using fast power recovery theory. The Shunt section of the UPQC removes current harmonic related problems in the system and the Series APF connected to the system removes all voltage harmonics arising from the indirect load placed at user end. The UPQC system has been developed and thoroughly discussed:

Simulink models for Shunt APF, Series APF, and UPQC have been created.

The Shunt APF model created the use of "PQ0 idea," and the modern hysteresis controller was used as the control approach.

Series APF used hysteresis power controller for the controlling technique to mitigate the voltage disturbance. By the use of Series transformer the dip/swell is reduced and the voltage supply is fully adjusted.

The UPQC model created with the aid of connecting the Shunt APF and lower back series APF with a DC capacitor. This Shunt APF mitigates harmonic present in main supply due to nonlinear load at user end.

A single or moderated model of the UPQC module has been proposed to cope with power troubles.



Power enhancement is completed with the use of multi-stage or multi-module control modes and intermediate controls of electrical disturbances.

UPQC flexibility to maximize the system capacity in the upcoming time and to address the increment of demands for low power distribution.

Economical power development model of UPQC has also been reviewed.

VII. FUTURE SCOPE

The UPQC version may be advanced and enriched to eliminate power quality issues in the power system. So with all advantages of UPQC it has been found that

- Laboratory prototype of this UPQC model can be created.
- A three-phase line system with linear load and unstable voltage can be modeled using the UPQC model.
- The UPQC model built in this case was the right UPQC shunt, and we can upgrade the left UPQC model also.
- We can connect renewable energy sources such as wind turbines and a solar power system with UPQC, both of which are required improvement during critical situations.
- It is difficult to prevent harmonics due to the presence of indirect load, but it is possible to control them, and much research is being done in this area.
- In recent years, researcher analysis focused on control and protection devices (CPDs) within the DG or micro grid system with UPQC control.
- Sliding Mode (SM) and response line control strategy are an improved version of UPQC because of their ease of use and the intensity of external signals.
- Additional DSPACE software, which acts as a bridge between real-time hardware and computers, can be used to implement the UPQC model using a new strategy known as the Fuzzy control system.

REFERENCES

- [1] P. M. Kadam1 and B. E. Kushare, "A Survey on Unified Power Quality Conditioner for Power Quality Improvement,"pp.23203331,[Online].Available:www.iosrjournals.org.
- [2] P.C.Sekhar,"Unified Power Quality Conditioner using PV Fed SVPWM based Multilevel Converters for Power Quality Improvement," Int. J. Innov. Technol. Explore Eng.,vol. 9, no. 6, pp. 1060–1064, 2020, doi: 10.35940/ijitee.f4160.049620.
- [3] M. S. Hamad, A. M. Fahmy, and M. Abdel-Geliel, "Power quality improvement of a single-phase grid connected PV system with fuzzy MPPT controller ,"IECONProc.(Industrial Electron. Conf.,pp. 1839–1844, 2013,doi: 10.1109/IECON.2013.6699411.
- [4] J. Li, F. Zhuo, X. Wang, L. Wang, and S. Ni, "A grid-connected PV system with powerquality improvement based on boost + dual-level four-leg inverter," 2009 IEEE 6th Int.PowerElectron.MotionControlConf.IPEMC'09,vol.3,pp.436– 440,2009,doi:10.1109/IPEMC.2009.5157427
- [5] A. R. Thorat, "Distribution Static compensator for Power Quality Improvement using PVArray,"Distrib. Static Compens. PowerQual. Improv.using PVArray. Digvijay,2015.
- [6] P. Raja Sekhar, S. Venkatrao, and A. Professor, "Mitigation of the Wind GenerationIntegration Related Power Quality Issues by Energy Storage," Int. J. Adv. Sci. Technol.Eng.Manag. Sci.,no.1,pp.2454–356, 2017,[Online]. Available:www.ijastems.org.
- [7] Y. Pal, A. Swarup, and B. Singh, "A novel control strategy of three-phase, four- wireUPQC for power quality improvement,"J. Electrical Eng. Technol., vol. 7, no. 1, pp. 1– 8,2012,doi: 10.5370/JEET.2012.7.1.1.
- [8] P. Jenopaul, I. Jacob Raglend, and T. Ruban Deva Prakash, "Constant frequency-unified power quality conditioner,"2011Int.Conf.Emerg.TrendsElectr.Comput.Technol.ICETECT 2011, pp. 1–8,2011, doi: 10.1109/ICETECT.2011.5760078.
- [9] A. K. Jindal, A. Ghosh, and A. Joshi, "Interline unified power quality conditioner," IEEETrans.PowerDeliv.,vol.22,no.1,pp.364– 372,2007,doi:10.1109/TPWRD.2006.881581.



- [10] V. Khadkikar and A. Chandra, "A new control philosophy for a unified power quality conditioner (UPQC) to coordinate load-reactive power demand between shunt and series inverters," *IEEE Trans. Power Deliv.*, vol. 23, no. 4, pp. 2522-2534, 2008, doi:10.1109/TPWRD.2008.921146.
- [11] Y. Hoseynpoor, T. Pirzadeh Ashraf, and S. Sajedi, "Economic assessment of unified power quality controller operation in joint and separated modes with DG units," *Res. J. Appl. Sci. Eng. Technol.*, vol. 3, no. 9, pp. 963-967, 2011.

