

Real-Time Water Usage Monitoring and Secure Distribution System Using IoT and RFID for Rural Infrastructure

Prof. R.R.Pagire¹, Miss. Sanjana Yadav², Miss. Wamane Kirti³,

Miss. Tanvi Gorse⁴, Miss. Shweta Wathole⁵

Prof. Electrical Engineering Department¹

Students, AIDS Engineering Department^{2,3}

Student, Information & Technology Engineering Department⁴

Student, Computer Science Engineering Department⁵

Adsul's Technical Campus, Ahilyanagar, India^{1,2,3,4,5}

Abstract: *This paper presents a project on Drinking water vending machine. A vending machine is a machine that gives out different kinds of products when a person inserts RFID CARD into it; therefore it is a RFID based vending machine. These machines can be implemented using various methods but in this project it has been implemented using PIC microcontroller. Vending machines makes it easier for making small purchases, it occupies less space and it doesn't need any continuous monitoring. These machines were first introduced in England in the early 19th century. The rapid growth of the Internet of Things (IoT) changes human's life into a smart world. Physical objects connected with smart sensors provide data to make people's life easier. We present a case study of the smart water dispenser is with the aid of weight sensor, temperature sensor, and raspberry is built to assists the users and the water bottle suppliers by tracking the amount of water used in day to day activity. The smart water dispenser measures the weight of the available water in the dispenser and pops an alert when the water in the dispenser is about to finish. It measures the temperature and pushes notifications to the user about water consumption. Here we put forward a fully automated RFID based water dispenser system using Arduino and Relay. The system is capable of fully automated water dispensing using solenoid tap and sensors. Here one master controller and no of slaves according to no. of users are there. Master keeps data for each user used how much amount of water and how much is remaining. Buzzers are provided to each user for acknowledgement.*

Keywords: RFID Tag, Water Management, IOT Web Server, Microcontroller

I. INTRODUCTION

Now a day's water vending machines are available and operated on only one coin but our aim is to design water vending machine which operates on smartcards. In India there is problem of safe drinking water therefore we are going to provide mineral water. Water has become the most commercial products of the century. This may sound bizarre, but true. The stress on the multiple water resources is a result of a multitude of factors. On the one hand, the rapidly rising population and changing lifestyles have increased the need for fresh water. So is the panic over drinking water supply in the city as well as in villages. The reservoir has just 35.63 feet of water, which is not even half of the total water level. With the present arrangement of reduced frequency of water supply. Meanwhile, other sources of water such as tanks have dried up. As the problem of water shortage has been increasing by the day, slum-dwellers are being forced to fetch water from other sources located at a distance from their houses. There have been reports of quarrels between slum-dwellers over fetching water from public taps





The vending machines first came into the market in the 18th century, and then modern vending machines came up in the 19th century with the help of modern technologies. The word vending is a Greek word, which means selling. The first modern commercial RFID based vending machine was introduced in London and England for the purpose of selling postcards. The Vending machine is simply a machine, which works automatically and can sell out canned soups, packed eatables, chocolates, candies, snacks, even hot drinks such as coffee, tea, hot chocolate and also drinks like juices, soda water, plain water, and even sometimes some sort of stationery. Therefore, it is also known as Automatic Dispense Machine. These machines are more reliable, easily accessible and much more practical than the convention method of purchase. Nowadays these machines are found almost everywhere like at schools, rural area, offices, small restaurants for selling snacks and drinks, even found at railway stations for selling tickets and thus avoiding the queue and in turn saves time. This machine has a huge market with high annual revenues for both developed and developing countries. Gradually, vending machines became a wide channel with increase in sales and even the competition between the manufacturers. It does have many benefits, first benefit is in terms of setup, it is easy to setup a vending machine because it occupies very less space and is compact in size, it is a low cost driven machine and can provide various products as the output. For example, the cold drink vending machine, ice-cream vending machine, chocolate vending machine, water or tea or coffee vending machines, etc. are invading the shops in this century. ATM (Automatic Teller Machine) is the best example of technology evolution in terms of vending machine in an engineering field. ATMs reduces the time and human efforts required to search, recognize and stand in a queue for cash payments and even for cash withdrawals.

II. LITERATURE SURVEY

For our project we are surveying some reports and references which are helping us to make it easy and simplest and they are as follows

Delhi Jal Board developed a decentralized approach for the potable-water distribution and supply infrastructure system. "Water ATMs" provide pay-per-use water for local residents to fill personal canisters with [5]. This system is located in the Sawda Ghevra colony, located in the northwest corner of Delhi, and provides sanitary water for United States cents per litre. Participants in this program use rechargeable prepaid smart cards. Water sanitation plays an important role in maintaining the water in hygienic way [6]. Water management should also focus on the water cycle, based on the seasons. This will reduce the environmental impact of water in day to day life [7]. Urban Decision Support System (UDSS) – is a wireless device works in a mobile app using the sensors attached to water appliances in order to collect data about the water usage [8]. Information about every mechanism of water usage is wirelessly recorded and sent to UDSS App on the user’s mobile device which analyses which appliance is consuming more water. Later, these practices are discouraged in order to reduce the water consumption. In recent times, various measures are being taken to get rid of water scarcity. The Satyamev Jayate Water Cup has done a good work of solving the water crisis in Maharashtra and it gave a sense of pride and confidence to the people of that region [9]. According to the study given in [10], based on the population of the cities, the water is being consumed. In every region, water is mainly consumed for domestic households. Also in some regions, water is consumed for commercial, industrial and civic or public use. In metropolitan cities, the minimum water requirement is about 150lpcd (litres per capita per day) and in non-metropolitan cities, it is 135lpcd. For industrial and commercial use, it takes about 74lpcd. Therefore, minimum sufficient requirement of water must be reachable to the people.

III. METHODOLOGY

In drinking water management system, if there are number of user for a common drinking water tank. In such case water management is very necessary. This project does the water distribution management; here one master is present which can communicate with different slave controllers. Different slave controllers are provided to different water users. Microcontroller PIC18F4520 is used at master as well as at slave. Slave controller will be ON and OFF according to order of master. Slave controller provides water to user of fixed amount.



As water supply for all user is complete master makes motor driver relay off. One facility is proved here as water supply starts to user the buzzer placed in his house stats ringing for acknowledge.

From the main supply the AC voltage is continuously supplied to the vending machine. There is a diode rectifier in the circuit, which converts the AC voltage into DC, and this voltage is supplied to a voltage regulator (7805 IC) through an electrolytic capacitor present at the rectifier. The capacitor stores some voltage and provides the smooth voltage to the regulator. The regulator converts the voltage supplied to a constant voltage of 5V. An LED is present in the circuit to indicate the working, with a resistor to drop the voltage because an LED needs very less voltage to operate. The 5V supply is supplied to the pin 1st pin of the controller, which is an input/output pin, is connected to the 1st pin of drive circuit, which is an input pin of the first channel. The pin of the drive circuit is the output pin of the first channel is supplied with 0V because the 1st and the drive circuit pin are inverse to each other. This drive circuit pin is connected to a relay, which is connected to two switches, which are used to select the required product. The relay switch acts as a driver and a protector.

The pin of the drive circuit is connected to the „NO“ of the relay, which therefore acts as a ground. The 5V generated at the voltage regulator is then supplied to the common of the relay, which is used to drive the solenoid valve required. When the product required is selected and the RFID is inserted and if accepted by the card receives a pulse is given to the controller and the respective relay is driven which in-turn drives the solenoid valve attached to it.

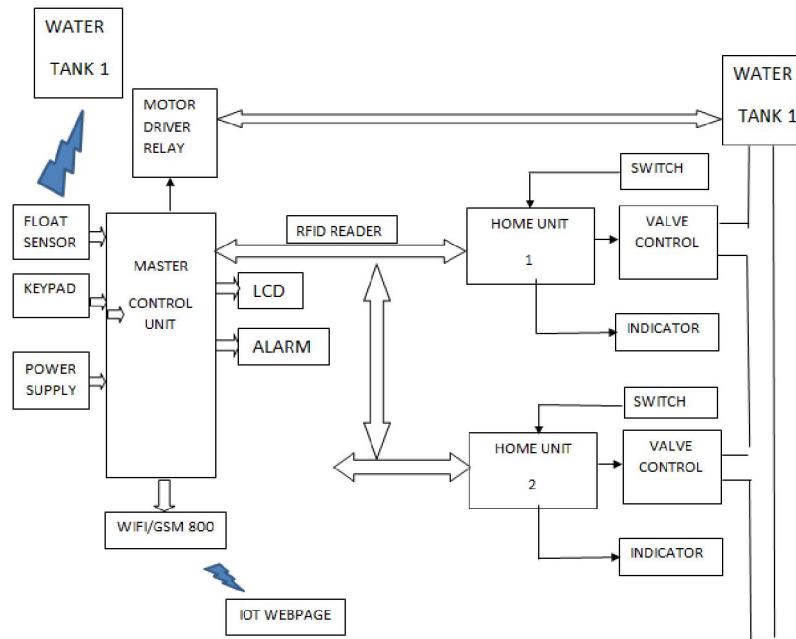

Fig. 1. Block Diagram

A. PIC18f4520 Microcontroller

The PIC18F4520 is a 28/40/44-Pin, High-Performance, Enhanced Flash, USB Microcontrollers with nanoWatt Technology. The following are the features:-

- High-Current Sink/Source: 25 mA/25 mA
- Three External Interrupts
- Four Timer modules (Timer0 to Timer3)
- Up to 2 Capture/Compare/PWM (CCP) modules:
 - Capture is 16-bit, max. resolution 5.2 ns (TCY/16)
 - Compare is 16-bit, max. resolution 83.3 ns (TCY)



- PWM output: PWM resolution is 1 to 10-bit
- Enhanced Capture/Compare/PWM (ECCP) module:
 - Multiple output modes
 - Selectable polarity
 - Programmable dead time
 - Auto-shutdown and auto-restart
- Enhanced USART module: LIN bus support



Fig. 2. PIC 18f4520

B. LCD Display

LCD (Liquid Crystal Display) screen is an electronic display module and find a wide range of applications. A 16x2LCD display is very basic module and is very commonly used in various devices and circuits. These modules are preferred over seven segments and other multi segment LEDs. The reasons being: LCDs are economical; easily programmable; have no limitation of displaying special & even custom characters (unlike in seven segments), animations and so on. A 16x2 LCD means it can display 16 characters per line and there are 2 such lines. In this LCD each character is displayed in 5x7 pixel matrix. This LCD has two registers, namely, Command and Data. The command register stores the command instructions given to the LCD. A command is an instruction given to LCD to do a predefined task like initializing it, clearing its screen, setting the cursor position, controlling display etc. The data register stores the data to be displayed on the LCD.

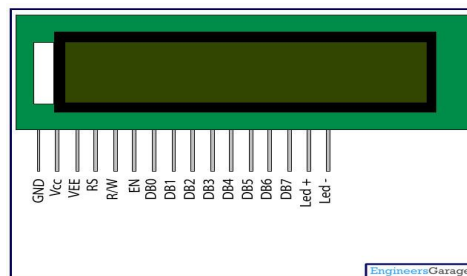

Fig. 3. LCD Display

C. RFID Reader

RF ID is Radio Frequency Identification which is used to make track of every physical object. The frequency of operation widely used at present are LF –Low Frequency 125 KHz & UHF (Mifare) 13.5MHz. The main components of the RF ID system are :

- 1) The RF ID Reader – EM-18 type of RFID reader is used for demo in this post.
- 2) RF ID tag – The Tag contains an Integrated circuit for memory & an Antenna coil.

There are 2 types of Tags – Passive & Active. We make use of Passive tags here .As the name implies these tags do not have a power source .When the passive Tag is near a RF ID reader, the energy is induced by electromagnetic





waves. The tag “wakes up” & responds by sending the data stored in its memory. The RANGE of passive tag access is below 10 cm.

Active tags have their own battery source & offer a long range of access. Active tags are costlier than the passive ones.



Fig. 4. RFID Reader

D. Thingspeak IOT

“The Internet of Things (IoT) is a system of interrelated computing devices, mechanical and digital machines, objects, animals or people that are provided with unique identifiers and the ability to transfer data over a network without requiring human-to-human or human-to-computer interaction.”

Things are either sensors or actuators. A sensor is something that tells us about our environment. Think of a temperature sensor, or even the GPS receiver on your mobile phone. Actuators are something that you want to control, things like thermostats, lights, pumps, and outlets. The “Internet of Things” brings everything together and allows us to interact with our things. For example, you could have your thermostat control itself based on where you’re located.

E. GSM SIM 800

The Sim800C GPRS/GSM Shield with Antenna provides you with a way to use the GSM phone network to receive data from a remote location and it is compatible with all boards which have the same form factor (and pinout) as a standard Arduino Board. This shield can also be applied to DIY phones for calling, receiving and sending messages, making GPS trackers or other applications like Smart home, etc.



Fig. 6. GSM SIM 800

IV. CONCLUSION

As Increased intelligence of every day, sensor objects implemented in devices offers opportunities for new applications and services. Multisensory integration is a very promising approach for robust monitoring and understanding of the measurement context. A cloud-based solution allows seamless integration with a standard infrastructure for a large number of users but requires higher power consumption. The smart water dispenser can be improved with a lot more



facilities in the future. Particularly by attaching an RFID reader to the dispenser we can track the amount of water every person has consumed in the day.

- IoT Enabled Water Distribution System can be useful for monitoring, tracing and manage the remote location valves and meters. In conventional systems, a person has handled such remote location valves and meter management. The main aim of this idea is to focus on various applications of IoT in water distribution which reduces the human effort and overcome the drawbacks in the conventional system.
- The water supplying is OFF whenever the water level reaches the allocated quantity. Whenever a user request an order for the extra water, then the order is placed RFID through immediately and then the water is supplied to the specified user.

REFERENCES

1. www.electronicsforu.com_circuitdigest.com www.researchgate.net create.arduino.cc
2. H. Montoya, B. Dong, S. Biswas, and K. A. Pfeiffer, "Use of a Wireless Network of Accelerometers for Improved Measurement of," Human Energy Expenditure, Electronics,
3. vol. 3, no. 2, pp. 205–220, 4 2014.
4. Amft, D. Bannach, G. Pirkl, M. Kreil, and P. Lukowicz, Towards a wearable sensing-based assessment of fluid intake, 2010.
5. M. C. Chiu, S. P. Chang, Y. C. Chang, H. H. Chu, C. C. H. Chen, F.-H. Hsiao, and J.-C. Ko, "Playful Bottle: A Mobile Intake," New York, NY, USA, 2009, pp. 185–194.
6. ElProCus - Electronic Projects for Engineering Students. (2017). Heat Sensor Circuit And Its Working Principle. [online] Available at: <https://www.elprocus.com/heat-sensor-circuit-and-working-operation/> [Accessed 9 Oct. 2017]

