

# Advanced Smart Helmet for Real-Time Rider Safety and Accident Avoidance Using IoT

Prof. R. R. Pagire<sup>1</sup>, Miss. Shruti Tandale<sup>2</sup>, Miss. Vishakha mhaske<sup>3</sup>,  
Miss. Vaishnavi Thombare<sup>4</sup>, Miss. Vaishnavi Suse<sup>5</sup>

Prof. Electrical Engineering Department, Adsul's Technical Campus, Ahilyanagar, India <sup>1</sup>

Students, AIDS Engineering Department, Adsul's Technical Campus, Ahilyanagar, India <sup>2,3,4</sup>

Student, Information & Technology Engineering Department, Adsul's Technical Campus, Ahilyanagar, India <sup>5</sup>

**Abstract:** *The around the world a large percentage of people die from road accident, especially in case of two wheelers. This may be avoided by emergency treatment of victim, wearing helmets and riding vehicles without consuming alcohol. The IoT-Based Bike Rider Safety Monitoring System enhances road safety by ensuring that the rider follows essential precautions before and during the ride. The system consists of two primary components: the Helmet Unit and the Bike Unit, which work together to enforce safety measures and provide real-time data through IoT cloud integration. This cloud-based system enables remote monitoring, alerts, and data-driven decision-making to improve accident prevention and emergency response. In this project we will use PIC 18f4520 microcontroller. All parameter will display on LCD display. Throughout the ride, all safety parameters—helmet status, alcohol detection, side stand position, Accident Detection and accident data—are continuously logged in the IoT cloud. This data can be accessed in real-time via a web dashboard or mobile application, allowing remote tracking of the bike's safety conditions.*

**Keywords:** Bike Rider Safety, IOT, Smart Helmet, Quick Alerting, Wireless Communication, Accident Detection

## I. INTRODUCTION

The According to the law of the Indian government as per section 129 of the motor vehicle act of 1988 briefly explains the motorcycle or two-wheeler rider is mandatory to wear the helmet while driving and the recent survey conducted on road accidents by the world health organization (WHO). This WHO organization has briefly mentioned the cause and the prevention of road accidents that are happened around the world. They also mentioned the highest death rate that took place in India and the survey also reported as per the rate 1.5 lakh of road death has been accounted for by each year approximately. The above article motivates us to develop a system that is capable of providing safety and precaution to the bike rider. We designed a system that is capable of detecting the rider is whether wearing the helmet or not. Then detecting if the rider has consumed alcohol or not, whether if these two conditions are yet satisfied then only the motor will ignite or else it will not ignite. In case an accident occurred, our system is capable of detecting the accident and its location approximately. We implanted the led strip indication in the helmet unit to reduce the percentage of an accident during night times.

The idea of the Smart helmet is done completely for the betterment of society. Two wheelers should use this Smart helmet and it is developed such that without this helmet the vehicle's ignition will not start. So this will warn the rider at the very beginning of his journey! And in recent days helmets have become compulsory in accordance with the (section 129) Act of Motor vehicles. It has strictly stated that each and every person traveling on a two-wheeler must wear protective headgear. This protects the rider from at most carelessness like riding without proper knowledge-rules, no proper condition of the bike etc. One main reason the fatality rate in mishap is rising is due to the delay and lack of proper treatment in time and No immediate response from society to inform the police and the hospital. Many have lost their life in this case. Saving life in golden hours matters a lot here. So, we must not let time take any life. The Smart



helmet also helps the traffic police and follows government regulations. The device is completely safe for use of two wheeler riders.

This may be avoided by emergency treatment of victim, wearing helmets and riding vehicles without consuming alcohol. An effective approach is made to solve the problem by using Smart Helmet. Here, Smart Helmet is acting as a key. If the driver has consumed alcohol, the sensor will sense it and immediately lock the engine. Smart helmet provides help in case of accident by using GSM and GPS technology. If the person is met with an accident, then in such situation a message along with the location is sent to the ambulance or family member so that medical aid can be provided to that person as soon as possible. The project aims at intelligence security providing awareness for wearing helmet and also provides prevention for human life safety. In this project we will use PIC 18f4520 microcontroller. All parameter will display on LCD display. To detect alcohol consumption of the rider we use Alcohol sensor.

## II. LITERATURE REVIEW

According to the recent Research paper in 2016 titled '2 Helmet using GSM and GPS technology for accident detection and reporting system', the author specially developed this project to improve the safety of the bikers. The objective of this project is to Study and understand the concept of RF transmitter and RF receiver circuit. The project uses ARM7, GSM and GPS module. The Project also uses buzzer for indication purpose. Whenever the accident will occur then accident spot will be note down and Information will send out on the registered mobile number. [2] The major disadvantage of this project is they are not using any Display device for showing the current status. Also the cost of helmet is still high since helmet is designed for only one purpose. According to the Research paper in 2015 titled 'Microcontroller based smart wear for driver safety', In this paper author has Discussed on the speed of the vehicle. In this application the project will be monitoring the areas in which the vehicle will be passing. On entering any cautionary areas like schools, hospitals, etc the speed of the vehicle will be controlled to a predefined limit. LCD Is used for showing the various types of messages after wearing the helmet. The author has worked only on the phenomenon of Accident which is generally happens due to drunk and drive. But as we know that the accident in the area is not happens only due To consuming alcohol but also other parameters like speed are also responsible. According to the Research paper in 2016 titled 'Smart Helmet', In this paper the main objective of author is to force the rider to Wear the helmet. In this competitive world one of the surveys says that the death trolls due to motor bike accidents are increasing Day by day out of which most of these casualties occurs because of the absence of helmet. Traffic police cannot cover remote roads Of city. That's why over primary objective is to make the usage of the helmet for two wheelers "compulsory " .Thus ,no one other than the owner himself ,who doesn't have "password" which would have been created by the owner, can use the bike. In this author has proposed the feature that the bike will not start unless the bike rider does not wear the helmet .The other this module basically deals with the checksum of rider if he is wearing the helmet or not on first place to achieve this ultrasonic sensor is been used .based on this the signal are been sent to the next module voice recognition module use for authentication purpose. Arduino is also used in this project which is an open source tool for making computer that can sense.

Nowadays most of the people's day can't get over without internet. In such case the embedded devices get connected to the internet which is a platform called internet of things [1]. The main reason for deaths happening in our country is the road accident, which is not recovered by the police immediately. So the nearby police department should be notified immediately so that the police urge them to take to the nearby hospital [2]. In this paper it is clearly listed, that one of the main reason for the road accidents is the alcohol consumption of the person. Careless driving of the rider can also be taken as a consideration for the road accident to rectify that IR sensor is used to detect the obstacles to keep the rider in a safe zone [3]. This paper put forth the solution for the safe driving of the rider .the smart helmet consists of breath alcohol sensitizer to know the state of mind and the alcohol consumption of the rider. Suppose if the person is listening to the music using smart mp3 player where the sound can be adjusted automatically for the safety precautions of the rider [4]. Wearing helmet is a must during driving. So to notify the people with the automatic SMS, a relay should be connected along with the receiver module where the signal is transmitted from the transmitter of the helmet [5].MQ3



sensor checks whether the person has drunk and having non-alcoholic breathe. Then the switch placed in the helmet powers the helmet and pressures the sensor to wear the helmet [6].

### III. METHODOLOGY

The project methodology is given below:

- **Helmet Authentication-** To ensure that the bike rider is wearing a helmet or not.
- **Alcohol Detection-** To ensure that the bike rider has not consumed alcohol (using MQ3 Gas Sensor).
- **Response System-** in the helmet in case of accident, to inform bike rider's family about the accident using GPS & GSM module Helmet.
- **Fall Detection-** in case of accident, to inform bike rider's family about the accident and Accident will be detected by using accelerometer.

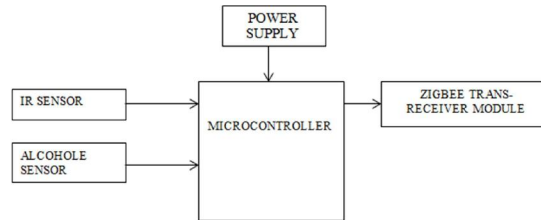

Fig. 1. Block Diagram (Helmet Unit)

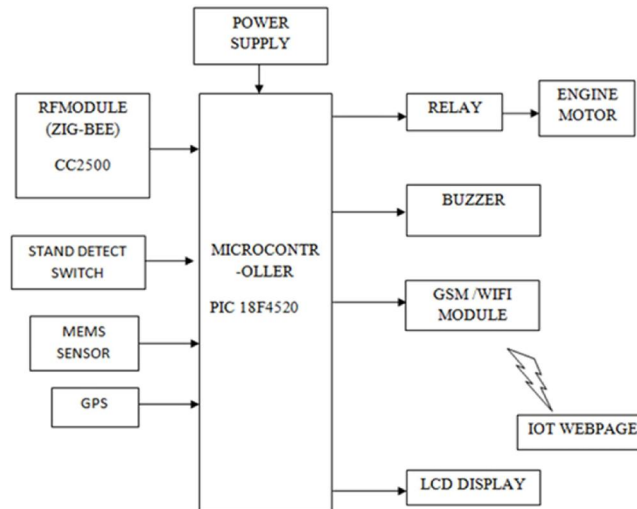

Fig. 2. Block Diagram (Bike Unit)

Helmet Unit serves as the first checkpoint for ensuring rider safety. It includes an Infrared (IR) sensor to detect whether the helmet is worn and an MQ-3 alcohol sensor to check for alcohol consumption. These sensors send real-time data to the Bike Unit and the IoT cloud, ensuring that safety compliance is monitored at all times. If the helmet is not worn or alcohol is detected beyond the threshold, the system immediately blocks bike ignition and logs the violation in the IoT cloud. This cloud integration allows fleet managers, traffic authorities, or family members to access safety data remotely and receive alerts in case of non-compliance. If all safety conditions are met, the RF transmitter module sends a signal to the Bike Unit, permitting ignition.

Once the Helmet Unit authenticates the rider, the Bike Unit ensures that the vehicle is in a safe operating condition before and during the ride. The HC12 RF receiver module in the Bike Unit receives authentication data from the Helmet Unit, allowing the bike to start only if all conditions are met. A Hall Effect sensor is integrated to detect



whether the side stand is engaged; if the stand is down, the bike remains locked, a warning message is displayed on the LCD screen, and the event is recorded in the IoT cloud for safety tracking.

Additionally, the LCD display on the Bike Unit provides real-time updates stand, helmet, alcohol status. In case of an accident; vibration and impact sensors detect abnormal movements or collisions. The microcontroller processes this data and triggers the GSM module, which sends an emergency SMS alert with the rider's GPS location to emergency contacts. Simultaneously, the accident data, including location, time, and impact severity, is uploaded to the IoT cloud, allowing quick access for emergency responders. This feature significantly reduces response time and improves post-accident investigation efficiency.

#### A. PIC18f4520 Microcontroller

It is an 8-bit enhanced flash PIC microcontroller that comes with nano Watt technology and is based on RISC architecture. Many electronic applications house this controller and cover wide areas ranging from home appliances, industrial automation, and security system and end-user products. This microcontroller has made a renowned place in the market and becomes a major concern for university students for designing their projects, setting them free from the use of a plethora of components for a specific purpose, as this controller comes with inbuilt peripheral with the ability to perform multiple functions on a single chip.

- Data Memory up to 4k bytes Data register map - with 12-bit address bus 000-FFF
- Divided into 256-byte banks
- Half of bank 0 and half of bank 15 form a virtual (or access) bank that is accessible no matter which bank is selected – this selection is done via 8-bit
- Program memory is 16-bits wide accessed through a separate program data bus and address bus inside the PIC18.
- Program memory stores the program and also static data in the system.
- On-chip program memory is either PROM or EEPROM.



Fig. 3. PIC 18f4520 Microcontroller

#### B. Alcohol Sensor

The MQ3 sensor is one of the most widely used in the MQ sensor series. It is a MOS (Metal Oxide Semiconductor) sensor. Metal oxide sensors are also known as Chemiresistors because sensing is based on the change in resistance of the sensing material when exposed to alcohol.



Fig.4. Alcohol Sensor

#### C. HC-12 Wireless Trans receiver Module

HC-12 wireless RF UART communication module is a new generation of multi-channel embedded wireless data transmission module. The Radio frequency of 433.4 – 473.0MHz, can be setting a communication channel, step is



400kHz, a total of 100 channels. The module maximum transmit power is 100mW (20dBm), and -116dBm receiver sensitivity air of the 5000bps baud rate, communication distance about 500 meter.

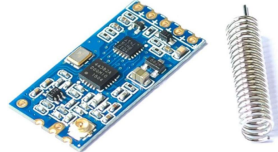

Fig.5. HC12 Wireless Trans-receiver Module

#### D. ADXL 335 Sensor

The ADXL335 is a small, thin, low-power, complete 3-axis accelerometer with signal conditioned voltage outputs. The ADXL335 Module 3-axis Analog Output Accelerometer measures acceleration with a minimum full scale range of  $\pm 3$  g.

It can measure the static acceleration of gravity in tilt-sensing applications, as well as dynamic acceleration resulting from motion, shock, or vibration. This breakout board comes with an onboard voltage regulator and works at both 3.3V & 5V (3-5V).

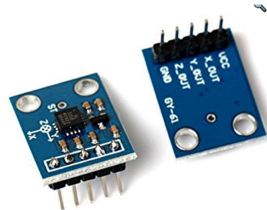

Fig -6: ADXL 335 MEMS Sensor

#### E. GSM Module

IGSM SIM800C Modem with Antenna Module's baud rate is configurable from 9600-115200 through AT command. The GSM GPRS Modem is having internal TCP/IP stack to enable you to connect with the internet via GPRS. It is suitable for SMS, Voice as well as DATA transfer applications in the M2M interface.

The onboard Regulated Power supply allows you to connect a wide range of unregulated power supply. Using this modem, you can make audio calls, SMS, Read SMS, attend the incoming calls and internet, etc through simple AT commands.



Fig. 7. GSM Module

#### F. LCD Display

A 16x2 LCD means it can display 16 characters per line and there are 2 such lines. In this LCD each character is displayed in 5x7 pixel matrix. This LCD has two registers, namely, Command and Data. The command register stores the command instructions given to the LCD. A command is an instruction given to LCD to do a predefined task like initializing it, clearing its screen, setting the cursor position, controlling display etc. The data register stores the data to be displayed on the LCD.



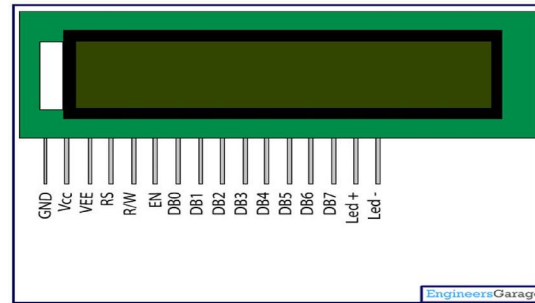

Fig. 9. LCD Display

### G. Internet of Things(IoT)

ThingSpeak is an IoT platform from MathWorks, the makers of MATLAB, that allows you to collect, store, visualize, and analyze data from IoT devices in the cloud, offering features like real-time data streams, MATLAB analytics, and event-based alerts.

- Cloud Data Storage and Aggregation: ThingSpeak provides a cloud-based service to store and aggregate data from various IoT devices.
- Real-time Data Visualization: You can visualize your data in real-time with charts and graphs directly within the ThingSpeak platform

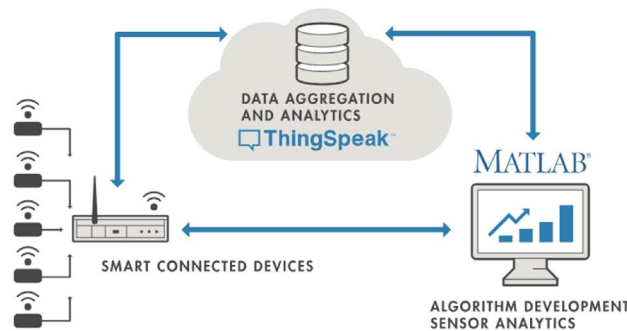

Fig. 10. Things Speak IOT

### IV. CONCLUSION

The IoT-Based Bike Rider Safety Monitoring System enhances road safety by ensuring that the rider follows essential precautions before and during the ride. This smart safety helmet enables users to control the bike unit easily; it reduces the nuisance caused by a drunken driver. Also, it adds on to the preventing of any unwanted accidents that happen due to alcohol consumption or due to the negligence of helmet by the rider. It acts as a safety measure to the rider; it significantly reduces the accident possibilities. The user has to wear a helmet to ride the vehicle, and hence, traffic rules will follow with this. This system is under pocket control, i.e., the two-wheeled vehicle having safety and, in the budget, also. This easy and efficient functioning system provides better safety and security to the riders.

Throughout the ride, all safety parameters—helmet status, alcohol detection, side stand position, oil level, obstacle warnings, and accident data—are continuously logged in the IoT cloud. This data can be accessed in real-time via a web dashboard or mobile application, allowing remote tracking of the bike's safety conditions. The IoT cloud integration provides key benefits such as:

Advantages-

- Real-time monitoring of rider safety compliance.
- Instant alerts for non-compliance, accidents, and unsafe riding conditions.



- Long-term data storage and analytics for improving road safety.
- Remote access for authorities and fleet managers to track rider behaviour.
- Faster emergency response through automated accident reporting.

## V. FUTURE SCOPE

The IoT-Based Bike Rider Safety Monitoring System has the potential to evolve into a more advanced and intelligent safety solution by integrating new technologies and expanding its applications. Below are some unique and future enhancements that can significantly improve the system:

- **AI-Based Accident Prediction and Prevention:** By incorporating Artificial Intelligence (AI) and Machine Learning (ML), the system can analyse riding patterns, speed, and environmental conditions to predict potential accidents. AI models can detect reckless driving behaviour and warn the rider in real-time before an accident occurs.
- **Integration with Smart Traffic Systems:** The system can be linked to smart traffic management systems to provide real-time data on road conditions, traffic congestion, and accident-prone zones. By integrating with city-wide IoT networks, emergency services can receive automatic alerts with precise location details, reducing response time.
- **Cloud-Based Data Storage and Monitoring:** A cloud-connected system can store real-time rider data, including helmet compliance; alcohol detection, speed monitoring, and accident reports. This data can be used for insurance claims, traffic law enforcement, and rider safety analysis.
- **Smart Helmet with Augmented Reality (AR) Display:** Future helmets can include an AR-based heads-up display (HUD) that provides navigation assistance, real-time alerts, and safety warnings. The display can also show speed limits, blind-spot detection alerts, and communication from emergency services.
- **Voice-Controlled and Gesture-Based Operation:** The system can integrate voice commands or gesture recognition to allow hands-free operation of safety features. Riders can interact with the system using voice inputs to check bike status, tire pressure, and safety conditions.
- **Integration with Smart Wearable Devices:** The helmet can be linked with smartwatches or fitness bands to monitor the rider's heart rate, fatigue levels, and overall health while riding. In case of abnormal health conditions (such as heart attack or dizziness), the system can automatically stop the bike and alert emergency contacts.
- **Automated Emergency Braking System:** Using AI-powered sensors and real-time obstacle detection, the system can activate an emergency braking mechanism to prevent collisions. This feature can reduce the impact of accidents caused by sudden obstacles or distracted riding.
- **Wireless Charging for Smart Helmet and Sensors:** Future versions of the system can include wireless charging stations for the smart helmet and bike sensors, ensuring continuous operation without manual recharging.
- **Integration with V2X (Vehicle-to-Everything) Communication:**

The system can connect with other vehicles, traffic signals, and infrastructure using V2X technology, enabling a safer riding experience. It can send alerts to nearby vehicles about sudden braking, accident detection, or approaching intersections.

## REFERENCES

- [1] International Journal of Scientific & Engineering Research Volume 2, Issue 12. December-2011 ISSN 2229-5518 IJSER
- [2] International Journal of Science and Research (ISR)ISSN (Online): 2319-7064 3) "Vehicle Accident Alert & Locator" UJECS-IENS Volume 11, Issue 02
- [3] [www.academia.edu/6541133/Smart\\_Helmet.php](http://www.academia.edu/6541133/Smart_Helmet.php)
- [4] IJSER) ISSN(Online):2319-7064 Vijay J. Saritha B. Priyadharshini B. Deepeka S and Laxmi R(2011), "Drunken Drive Protection System", International Journal of Scientific & Engineering Research. Vol.2.No. 12. ISSN:2229-5518
- [5] Dave Evans, "The Internet of Things How the Next Evolution of the Internet is changing everything"





[6] Jennifer William, Kaustubh Padwal, Nexon Samuel, Akshay Bawkar, SmitaRukhande, "Intelligent Helmet"- IJSER, Vol 7, Issue 3, March-2016 ISSN 2229-5518 Page:591 to 594.

[7] Mangesh Jadhawar, Gauri Kandepalli, Ashlesha Kohade, Rajkumar Komati titled "SMART HELMET SAFETY SYSTEM USING ATMEGA 32" in the IJRET, Vol No - 9, Issue No - 3, Sep 2016, Page no - 491 - 494

[8] Kavianand G , Padmapriya N "Brainwave and Alcohol Sensitizing Helmet for Riders Safety"- International Journal for Research in Applied Science & Engineering Technology, Volume 3 Issue III, March 2015, Volume 2, Issue 6, October-2015 ISSN 2229-5518 IJSER © 2015 Page:391 to 394

[9] Aviral Vijay, Ajay Singh, Bhanwar Veer Singh, Abhimanyu Yadav, Blessy Varghese and Ankit Vijay, "Hi-tech Helmet and Accidental Free Transportation System"- International Journal of Advanced Technology and Engineering Exploration ISSN (Print): 2394-5443 ISSN (Online): 2394-7454 Volume-2 Issue-6 May-2015

