

Solar Based Wireless Electric Vehicle Hybrid Charging System

Prof. Kunda Tarawade¹, Miss. Shruti Landage², Mr. Prem Shirale³, Mr. Shubham Gayke⁴, Miss. Snehal Janephalkar⁵

Prof, Electronics & Telecommunication Engg. Department, Adsul's Technical Campus, Ahilyanagar, India¹
Students, Computer Engineering Department, Adsul's Technical Campus, Ahilyanagar, India^{2,3,4}
Student, AIDS Engineering Department, Adsul's Technical Campus, Ahilyanagar, India⁵

Abstract: *The increasing adoption of electric vehicles (EVs) has intensified the demand for efficient, sustainable, and user-friendly charging technologies. Solar-based wireless charging systems offer a promising solution by integrating renewable energy generation with inductive power transfer to enable convenient, cable-free charging. This research work explores the design, operation, and performance evaluation of a solar-powered wireless EV charging system, highlighting the architecture, components, methodology, challenges, and potential applications. The proposed system uses solar photovoltaic (PV) modules to supply DC power, which is then conditioned and transmitted wirelessly through a resonant inductive coupling mechanism. Experimental analysis demonstrates the feasibility and efficiency of the system under different operating conditions. The results indicate that solar-assisted wireless charging can reduce dependence on grid power, minimize infrastructure complexity, and support the development of green transportation ecosystems.*

Keywords: Electric Vehicle (EV), Solar PV, Wireless Charging, Inductive Power Transfer (IPT), Resonant Coupling, Renewable Energy, Smart Mobility

I. INTRODUCTION

The rise of electric vehicles (EVs) signals a promising shift towards sustainable transportation, offering a solution to combat climate change and reduce reliance on fossil fuels. However, challenges persist in the charging infrastructure, with conventional stationary charging stations causing significant waiting times for vehicle owners. This hinders the seamless integration of EVs into mainstream transportation systems. To address this issue, our project aims to develop an innovative solution: the Solar Wireless Charging System in Electric Vehicles. By harnessing solar energy and wireless transmission technology, this system revolutionizes the EV charging landscape, enabling on-the-go charging to minimize downtime and enhance overall efficiency. Traditional charging systems are static, requiring vehicles to park at designated stations for extended periods, leading to increased waiting times, limited infrastructure availability, and grid integration challenges. Integrating renewable energy sources is crucial to facilitate widespread EV adoption. Earlier research focused on improving battery technologies but lacked renewable energy integration. Recent efforts have attempted to integrate solar power with EV charging, but most remain stationary, necessitating vehicle stops for charging. Developing an efficient solar wireless charging system requires specialist knowledge in solar power generation, wireless transmission, and electric vehicle design. Stakeholders include EV owners, manufacturers, urban planners, environmentalists, and government agencies focused on clean energy and transportation.

Electric vehicles have now hit the road worldwide and are slowly growing in numbers. Apart from environmental benefits electric vehicles have also proven helpful in reducing cost of travel by replacing fuel by electricity which is way cheaper. The system makes use of a solar panel, battery, transformer, regulator circuitry, copper coils, AC to DC converter, PIC micro controller and LCD display to develop the system. The system demonstrates how electric vehicles can be charged while moving on road, eliminating the need to stop for charging. The solar panel is used to power the battery through a charge controller. The battery is charged and stores dc power. The DC power now needs to be



converted to AC for transmission. For this purpose we here use a transformer. The power is converted to AC using transformer and the regulated using regulator circuitry. This power is now used to power the copper coils that are used for wireless energy transmission. A copper coil is also mounted underneath the electric vehicle. When the vehicle is driven over the coils energy is transmitted from the transmitter coil to ev coil. Please note the energy is still DC current that is induced into this coil. Now we convert this to DC again so that it can be used to charge the EV battery. We use AC to DC conversion circuitry to convert it back to DC current. Now we also measure the input voltage using an PIC micro controller microcontroller and display this on an LCD display. Thus the system demonstrates a solar powered wireless charging system for electric vehicle that can be integrated in the road.

Need of Project:

The motivation for this research paper is to tackle two main issues 1) Long charging time - takes 1-3 hours to charge. 2) Electric charging stations outside the city and in remote areas where there is no electricity. Here we have created an EV charging system that solves both of these problems with a unique and innovative solution. Here we have created an EV charger that solves two problems with a unique solution.

Objective:

- To design a wireless EV charging system powered by solar PV modules.
- To analyze the performance of inductive power transfer for EV charging.
- To develop a power conditioning and control mechanism for efficient energy transfer.
- To evaluate system efficiency under varying solar and load conditions.
- To identify the challenges and propose solutions for real-world implementation.

II. LITERATURE SURVEY

[1] Solar Wireless Electric Vehicle Charging System

Author: BRV Prasad, M Geethanjali, M Sonia, S Ganesh

This paper describes the design of solar powered charging station for charging of electric vehicle describes design of solar powered charging station for charging of electric vehicle that solves the key downside of fuel and pollution. Electric vehicles have now hit the road worldwide and are slowly growing in numbers. Apart from environmental benefits electric vehicles have also proven helpful in reducing cost of travel by replacing fuel by electricity which is way cheaper. Well here we develop an EV charging system that solves with a unique innovative solution. This EV charging of vehicles without any wires, No need of stop for charging, vehicle charges while moving, Solar power for keeping the charging system going,

[2] Solar Wireless Electric Vehicle Charging System

Author: Karim, Merazul Shafiq, Nahian Bin Zame, Tousif-ul Islam Hossain, MD.Sakib Shawon, Mehedi Azad

The number of countries with electric vehicles on the road is steadily rising. In addition to helping the environment, electric vehicles have proven useful in cutting down on transportation costs by substituting expensive fuel with much more affordable power. Here, we create a novel and effective answer to this problem by designing an electric vehicle charging infrastructure. There is no need to stop for charging because the EV can do so while it is in motion; the system is powered by solar energy; and there is no need for an additional power source.

[3] Wireless charging systems for electric vehicles

Author: Muhammad Amjad , Muhammad Farooq-i-Azam

Electric vehicles require fast, economical and reliable charging systems for efficient performance. Wireless charging systems remove the hassle to plug in the device to be charged when compared with the conventional wired charging systems. Moreover, wireless charging is considered to be environment and user friendly as the wires and mechanical connectors and related infrastructure are not required. This paper reviews the methods and techniques used for wireless charging in electric vehicles. First, the general techniques for wireless power transfer are described and explained.



[4] An Overview of Solar-Powered Electric Vehicle Charging in Vehicular Adhoc Network

Author: Farooque Azam, NeerajPriyadarshi, Haris h Nagar, Sunil Kumar & Akash Kumar Bhoi

With the rise of EVs, the demand of charging has necessitated the inclusion of renewable energy sources to supplement the grid. Intelligent transportation system (ITS) provides safety and comfort to the connected vehicle. Design of charging strategy to obtain optimal energy utilization poses the challenge to the researchers when both electric vehicle (EV) and charging stations are considered together in vehicular ad hoc network (VANET). Here, we first introduce the VANET environment in which the communication between EVs on the road, road side unit (RSU), and a traffic server takes place. Then, the overview of solar PV integration with grid to meet the demand in peak hour has been discussed.

III. METHOD OF DISEASE DETECTION

This block diagram represents a system powered by both solar energy and a transformer, managed by a PIC18F4520 microcontroller. The solar panel generates DC power, which is converted to a suitable voltage by a DC-to-DC converter and stored in a battery bank. Simultaneously, AC power from the transformer is converted to DC by an AC-to-DC converter and also charges the battery bank. The PIC16f886 microcontroller acts as the central control unit, monitoring and managing various aspects of the system. It receives inputs from sensors like an RFID reader, AC voltage sensor, battery voltage sensor, solar voltage sensor, and switches. Based on these inputs, the microcontroller controls various outputs. It drives an LCD display to show system information, activates a buzzer through a relay driver circuit for alerts, and controls wireless charging via another relay driver circuit. It also drives red and green LEDs for visual indications. Overall, the system intelligently manages power sources, monitors vital parameters, and provides user feedback and control through the microcontroller.

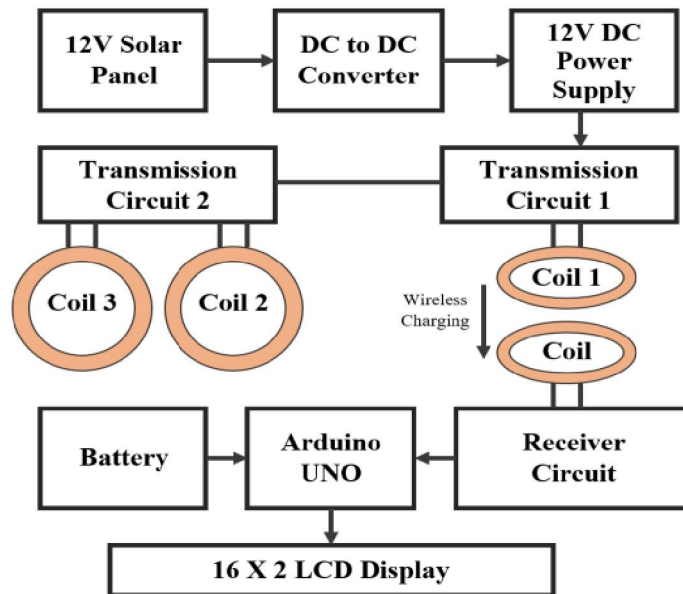

Fig. 1. Block Diagram

The main component of this system is the various ways of stepping down the incoming voltage. A conventional 220Vrms/50 Hz means is stepped down using the transformer to our required voltage and then converted to DC voltage. By using an inverter, the DC is converted to AC of our desired high frequency. The power is then transmitted through the transmitter coil to the receiver coil through inductive coupling. The receiver coil is placed at a particular distance and AC power is delivered at the end. This power is then rectified and regulated using a bridge rectifier and



Zener diode circuit. Afterwards, the energy is harnessed to charge the battery. The transmitter and the receiver coils were designed to achieve maximum quality factor to maximize power transfer at the frequency of operation. AC main from the grid is converted into high frequency AC through AC/DC and DC/AC converters to enable power transfer from transmission coil to the receiving coil. Series and parallel combinations-based compensation topology are used in both receiving and transmitting sides to improve the overall system efficiency [6]. Receiving coils are fixed under the vehicle to convert the oscillating magnetic field to high frequency AC. The high frequency AC is converted into a stable DC supply which can be used by the on-board batteries. To avoid any kind of health and safety issues and stable operation the power control, communications, and battery management system (BMS) are used. To reduce any harmful leakage fluxes and to improve magnetic flux distribution, magnetic planar ferrite plates are used at both transmitter and receiver sides.

A. Arduino UnoMicrocontroller

The Arduino UNO R3 is a versatile microcontroller board based on the ATmega328P, offering 14 digital input/output pins (6 PWM), 6 analog inputs, and a 16 MHz ceramic resonator. With its USB connection and power options, it provides a user-friendly interface for programming and experimenting, making it ideal for beginners and advanced users alike in electronics and prototyping projects.

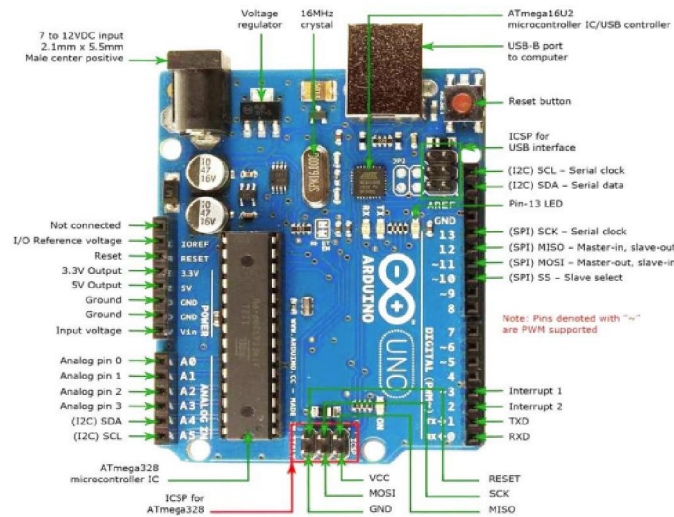

Fig. 3.Arduino0 Uno

B. Wireless Power Transmission coil

The Wireless Power Transfer and Charging Module can be used in electronic equipment's in common use for close wireless charging or power supply. Consist of a Transmitter & Receiver and coil, it could serve as a replacement for the Wireless Power Supply with stable 5V output voltage and maximum 600mA output current. Its small size and insulation coil is more suitable for using in wireless project.This module uses an electromagnetic field to transfer electric energy between a transmitter circuit and a receiver circuit. An induction coil creates an alternating electromagnetic field from within the transmitter circuit powered with 12V. The second induction coil takes power from the electromagnetic field and converts it back into electrical current to the receiver circuit that outputs 5V - 600mA.



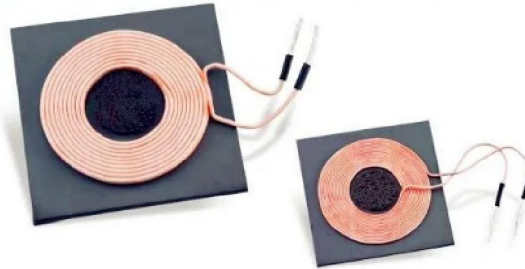

Fig. 4. Wireless Power Transmission Coils

C. Voltage Sensor

A voltage divider circuit is a simple and common way to create a voltage sensor. It's a passive linear circuit that produces an output voltage that's a fraction of its input voltage. Here's how it works:

Basic Principle:

- A voltage divider consists of two resistors (or impedances) connected in series.
- When a voltage is applied across the series combination, the voltage is divided between the resistors in proportion to their resistances.
- By measuring the voltage across one of the resistors, you can determine the input voltage.

The Formula:

- If you have two resistors, R1 and R2, in series, and an input voltage V_{in} , the output voltage V_{out} across R2 is given by:

$$V_{out} = V_{in} * (R2 / (R1 + R2)).$$

D. LCD Display

A 16x2 LCD means it can display 16 characters per line and there are 2 such lines. In this LCD each character is displayed in 5x7 pixel matrix. This LCD has two registers, namely, Command and Data. The command register stores the command instructions given to the LCD. A command is an instruction given to LCD to do a predefined task like initializing it, clearing its screen, setting the cursor position, controlling display etc. The data register stores the data to be displayed on the LCD.



Fig. 5. LCD Display



E. RFID Tag Reader

It is used to read unique ID from RFID tags. Whenever RFID tags comes in range, RFID reader reads its unique ID and transmits it serially to the microcontroller or PC. RFID reader has transceiver and an antenna mounted on it. It is mostly fixed in stationary position.

RFID Tag:RFID tag includes microchip with radio antenna mounted on substrate which carries 12 Byte unique Identification number.



Fig. 6.RFID Tag Reader

F. Transmitter Coil

Transmission Circuit 1 & 2 incorporate essential components such as resistors, capacitors, transistors, LEDs, and coils, enabling efficient signal amplification and wireless power transmission within the circuit.

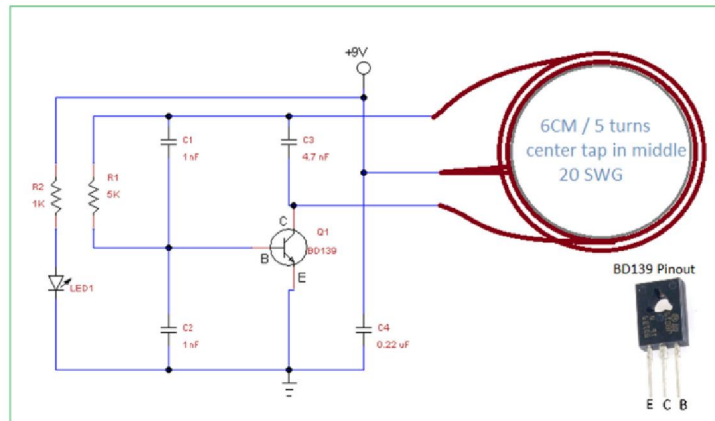

Fig. 6.Transmitter Circuit

G. Receiver Coil

The coil, bridge rectifier, capacitors, and IC 7805 are key components of the receiver circuit, working together to efficiently capture, rectify, and stabilize the wirelessly transmitted energy, ultimately providing a reliable and regulated power supply for connected electronic devices.



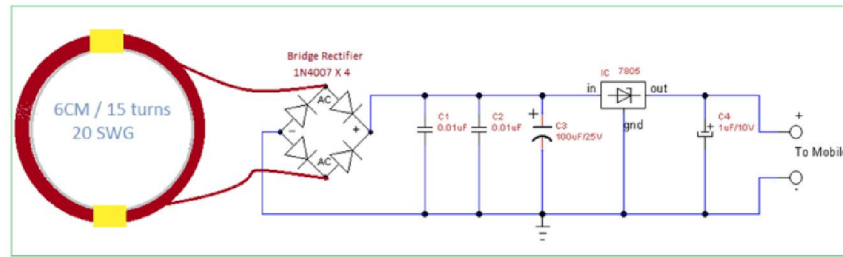

Fig. 7.Receiver Circuit

IV. CONCLUSION

The movement of automobile sector from conventional fossil fuelled vehicles to Electric vehicles are drastically increased. There is a requirement for more electric vehicles charging station in the roadsides of highways in regular intervals like the petrol pumps now. This electric charging increases the needs of more electricity. If the demand of electricity increases the respective department want to produce more electricity by hydro-power plant, thermal plants, etc. The use of fossil fuels also leads to environmental pollution. So we need a grid connected solar powered electric vehicle charging station. This can reduce the cost of battery for store charge in day time and provide charge for charging in night time, the efficiency of battery is also small. So by eliminating batteries we can improve the performance.

In conclusion, the Solar Wireless Electric Vehicle Charging System presents a transformative solution at the intersection of sustainability and technology. By harnessing solar energy and wireless transmission, it offers an efficient and convenient charging method for electric vehicles. With its Arduino-based control and monitoring capabilities, coupled with energy storage using 18650 batteries, this system not only reduces reliance on fossil fuels but also enhances user experience and accessibility. As we strive towards a greener future, innovations like these pave the way for more sustainable transportation solutions.

ACKNOWLEDGMENT

This is to acknowledgement of the intensive drive and technical competence of many individuals who have contributed to the success of my project. It gives us great pleasure in presenting the paper on “Solar Based Wireless Electric Vehicle Hybrid charging system”. We would like to take this opportunity to thank our guide, prof.KundaTarawade, Professor, Department of Electronics and Telecommunication Engineering, Adsul’s Technical Campus, Ahilyanagar for giving us all the help and guidance we needed. We are grateful to her for her kind support, and valuable suggestions were very helpful.

REFERENCES

- [1]. Kang Miao, Bidirectional battery charger for electric vehicles, Asia (ISGT Asia) 2018.
- [2]. Pinto, J. G. Bidirectional battery charger with Grid-to-vehicle, Vehicle -to-Grid and Vehicle-toHome technologies, IEEE 2020.
- [3]. Bugatha Ram Varaprasad, “Solar Powered BLDC Motor with HCC Fed Water Pumping System for Irrigation,” Int. J. Res. Appl. Sci. Eng. Technol., vol. 7, no. 3, pp. 788–796, 2019, doi: 10.22214/ijraset.2019.3137.
- [4]. Gallardo-Lozano, Milanes-Monster, GuerreroMartinez, Three-phase bidirectional battery charger for smart electric vehicles, International Conference-Workshop 2021.
- [5]. M. C. Kisacikoglu, “Vehicle-to-grid (V2G) reactive power operation analysis of the EV/PHEV bidirectional battery charger,” Ph.D. dissertation, University of Tennessee, Knoxville, 2019
- [6] Jacob Millman and Christos C. Halkias, —Integrated Electronics: Analog and Digital Circuits and Systems
- [7] Muhammad H. Rashid, —Power Electronics: Circuits, Devices, and Applications.



- [8] Robert L. Boylestad and Louis Nashelsky, Electronic Devices and Circuit Theory William H.Hayt,Jr. and John A.Buck, Engineering Electromagnetics https://en.wikipedia.org/wiki/Wireless_power
[9]Ahn, S., N. P. Suh, and D. H. Cho, Charging up the road, IEEE Spectrum, Vol. 50, No. 4, 48-54, 2013

