

# Experimental Investigation and Study of Fibre Reinforced Concrete by using Agave Plant Fibre

Prakash C<sup>1</sup> and Dr. R. Premsudha<sup>2</sup>

<sup>1</sup>PG Student Department of Civil Engineering

<sup>2</sup>Professor, and Head Department of Civil Engineering

Akshaya College of Engineering and Technology, Autonomous, Coimbatore

**Abstract:** *The conventional concrete is widely used construction material that is very good in carrying compressive forces and weak in carrying tension. To enhance the concrete good in tension, discrete fibers can be included to it to some extent. In this project, natural fibers obtained from MAGUEY FIBRE are used. Fibers in various proportions of 0, 1, and 2 percentages by volume fraction are added to M30 grade concrete. This project work deals with the comparative study of mechanical properties of Maguey Fibre Reinforced Concrete (MFRC) with conventional Concrete.*

**Keywords:** Maguey Fibre Reinforced Concrete, MFRC, Maguey Fibre

## I. INTRODUCTION

Composite construction is a generic term to describe any building construction involving multiple dissimilar materials. There are several reasons to use composite materials including increased strength, aesthetics and environmental sustainability. In structural engineering, composite construction exists when two different materials are bound together so strongly that they act together as a single unit from a structural point of view. When this occurs, it is called composite action.

Concrete is a mixture of cement, water, and aggregates, with or without admixtures. The cement and water will form a paste that hardens as a result of a chemical reaction between the cement and water. The paste acts as glue, binding the aggregates (sand and gravel or crushed stone) into a solid rock-like mass. The quality of the paste and the aggregates dictate the engineering properties of the construction material. During hydration and hardening, concrete will develop certain physical and chemical properties, among others, mechanical strength, low permeability and chemical and volume stability. Concrete has relatively high compressive strength, but significantly lower tensile strength.

Nevertheless, the construction industry continues to be the main consumer of energy in a world in which energy issues remain at the forefront of human conflict and global political/economic stability. Hence, the need for sustainable, energy efficient construction materials has oriented extensive research on alternative materials that can reduce the cost and environmental impact of construction processes. Two approaches have been explored: one includes the use of intrinsic modification (change in internal composition) to reduce the emissions associated with cement production, and the production of other construction materials. Examples of such approaches include the use of admixtures, limestone substitution and pozzolanic cements. The other approach includes the use of extrinsic modification (reinforcement with fibers) in the design of composites with attractive combinations of strength, stiffness, fracture toughness

/resistance-curve behavior and durability. The second approach will be the focus of this paper. Within this context, the composites may be reinforced with synthetic polymers such as polypropylene, rayon, nylon, polyester, Kevlar and carbon fibers. However; such fibers are generally not readily available in developing countries. Also, in cases where they are readily available, they may be too expensive to use in construction materials for affordable housing and come from a non-renewable source. On the other hand, Natural Fibers are a renewable resource and available in all countries in different forms. This has stimulated extensive research into the design of composites reinforced with natural fibers such as bamboo, sisal, maguey, coconut husks, sugar cane, banana leaf and wood fibers. Most of the initial efforts in this area have focused on the replacement of hazardous asbestos fibers with alternative natural fibers that are often



readily available as agricultural by-products with little or no current economic value. The incorporation of such natural fibers into cements and earth-based materials offers significant potential for the development of low-cost construction materials for affordable housing.

Therefore, to overcome these problems, here as an initiative and innovative maguey fibers were used as Natural Fibers added to concrete mix. On the other hand, the main drawbacks of all such natural fibers are their water sensitivity. All plant-derived cellulose fibers are hydrophilic in nature, mainly as a consequence of their chemical structure. Natural fibres have a good potential for chemical treatment due to presence of hydroxyl groups in lignin and cellulose. From various chemical pretreatment to overcome such drawbacks of water absorption, Mercerization, one of the most used chemical treatments is given to these fibers. Hence, experimental investigation and strength study on fiber reinforced concrete using maguey fiber in M30 concrete is made in this project.

## II. REVIEW OF LITERATURES

Tara Sen, H. N. Jagannatha Reddy. Among the various natural fibers such as, sisal fibers, bamboo fibers, coir fibers and jute fibers are of particular interest as these composites have high impact strength besides having moderate tensile and flexural properties compared to other lignocellulosic fibers. Also by considering the case of waste disposal, an attempt is made to study the possibilities of reusing the above natural fibres which not only has various applications but also helps to solve the problem of waste disposal atleast to a small extent.

Mahyuddin Ramli and Eethar Thanoon Dawood. This experimental investigation was carried out to study the properties of lightweight crushed brick concrete containing palm fiber of different volume fractions. An experimental programme was planned in which the tests such as density, compressive strength and flexural strength were conducted to investigate the properties of lightweight crushed brick concrete reinforced by palm fiber. The specimen incorporated different volume fractions of palm fiber, i.e., 0, 0.2, 0.4, 0.6, 0.8 and 1.0%. Test results showed that the use of this fiber slightly increases the density of lightweight concrete. The use of 0.8% of palm fiber increases the compressive strength and flexural strength by about 13.4 and 16.1% respectively. The results indicated that the use of palm fiber with lightweight crushed brick concrete enhances the mechanical properties of the concrete and the optimization of the palm fiber fractions is required to get the best performance.

Pratik Patel, Dr. Indrajit N. Patel. Main purpose of using fibers in concrete is to eliminate or lower down the shrinkage cracks developed and improve the flexural and split tensile strength of concrete. It cannot be used as reinforcement but it can lower down the requirement of reinforcement. Wood- cellulose fiber has relatively good mechanical properties compared with many man-made fibers such as polypropylene, polyethylene, polyester and acrylic. Addition of Cellulose fibers in concrete containing Silica Fume also improves the properties of concrete. Due to addition of Silica Fume in concrete there is well dispersion of fibers in concrete which directly affects the mechanical properties of the concrete. Fiber in larger percentage cannot use due to the problem of balling in concrete.

Abhijeet.R.Agrawal, Sanket.S.Dhase, Kautuk.S.Agrawal. The concluded result is that Coconut-fiber addition in the concrete increases the many properties of the concrete such as torsion, toughness and notably tensile strength which is the main properties of the concrete. Sometimes, it is noted that the coconut fiber which is to be used in the concrete will be available priceless which will make the concrete economy. It is noted that if there is increase in the percent of coconut fiber in the concrete than 3% of cement there is decrease in the strength of the concrete. The use of coconut fiber as reinforcement in the concrete will decrease the application of steel nearby 2% which is affordable with respect to the simply steel reinforced concrete and also increase the strength of the concrete. But it is not possible to use these fiber in the concrete which is used to build the malls, bungalows, commercial buildings etc. because it will not give the required strength but can de use to reinforce the non-structural components.

J.Sahaya Ruben, Dr.G.Baskar. Using coir fiber in civil construction reduces environmental pollution factors and may also bring several improvements in concrete characteristics. Coir fiber used in cement improves the resistance of concrete from sulphate attack. Compressive strength is also improved up to certain percentage. Addition of coir fiber also arrests the micro cracks present in the concrete.



Libo Yan\* and Nawawi Chow Natural fibres in different configurations can be used to replace conventional steel rebar as reinforcement of concrete structures. In addition, both sustainable concrete structures show good potential to be used in earthquake-prone zones. The application of these sustainable concrete structures is beneficial for consuming less energy, releasing less greenhouse gases into the atmosphere, and costing less to build and to maintain over time. Date palm trees are native to the middle-east region; their fibers can be easily and abundantly found in countries like the State of Qatar. The idea of reinforcing concrete with date palm fibers was studied by Kriker et al. (2005).

### III. EXPERIMENTAL INVESTIGATION AND ANSYS 15.0

All the materials tests were conducted in the laboratory as per relevant Indian Standard codes. Basic tests were conducted on fine aggregate, coarse aggregate, and cement to check their suitability for concrete making.

The study aims to investigate the strength related properties of concrete of M30 grade made using maguey fiber. The properties of maguey fibre were found through laboratory tests. The proportions of ingredients of the control concrete of grade M30 had to be determined by mix design as per IS code.

#### A. Experimental Investigation

Mix design is the process of selecting suitable ingredients of concrete and determining their relative proportion with the object of producing concrete of certain minimum strength and durability as economically as possible. The mix design of grade (M30) were determined and the mix is designed. As per IS 10262:2009. Trial mixes were made, tested and final mix proportion is arrived.

TABLE I. MIX PROPORTION

Concrete	Water	Cement	Fine Aggregate	Coarse Aggregate	Fiber
CC	0.43	1	1.17	2.23	0
MFR (2%)	0.43	1	1.16	2.20	0.018
UMFR (2%)	0.43	1	1.16	2.2.	0.017

#### B. Test Setup

The compressive strength test for cubes was conducted in compression testing machine as per IS 516 : 1964. The cubes were tested in compressive testing machine at the rate of 140 kg/cm<sup>2</sup>/min. and the ultimate loads were recorded.

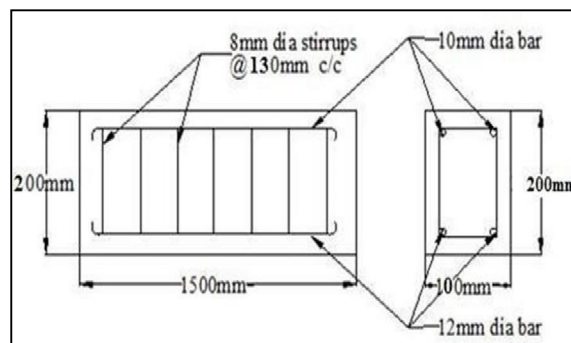

FIG I. RCC BEAM

The determination of flexural strength is essential to estimate the load at which the concrete members may crack. The flexural tests were carried out on beam specimens under standard two points loading was done conforming to IS516- 1959 (Reaffirmed-1999). The flexural strength is determined by testing standard test specimens of 100mm × 200mm × 1500mm under two pint loading. Load vs. deflections measurement are observed. The ultimate load at failure was noted.



The test set-up for the beam is shown in below. Two concentrated loads at one-third span were applied on beams. A dial gauge is fixed at themiddlespan of the set up. At the end of each load increment, observations and measurements were recorded for load points deflection, mid-point deflection and crack development. The load at first crack, ultimate load, type of failure etc., were carefully observed and recorded. The specimens were loaded continuously at a constant rate till failure.

The specimens are beams of size 100mm x 200mm x 1500mm, reinforced with 2 Nos of 12mm diameter HYSD bars in tension and 2 Nos of 10mm diameter HYSD bars in compression zone as hanger rods. The specimen is also provided with shear reinforcements in the form of 8mm diameter mild steel bar two legged stirrups at 130 mm center to center.

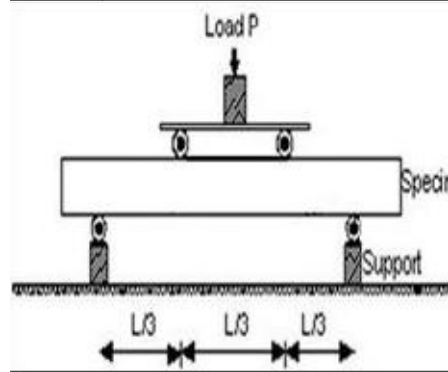

FIG 2. LOADING SETUP

TABLE 2. COMPRESSIVE STRENGTH

% Fiber	Age (Days)	Load (kN)	Compressive Strength (N/mm <sup>2</sup> )	Avg. Compressive Strength (N/mm <sup>2</sup> )
0%	28	740	32.88	33.1
		735	32.66	
		760	33.77	
Mercerized fiber	28	870	38.66	38.36
		840	37.33	
		880	39.11	
Unmercerizedfiber	28	800	35.55	36.44
		820	36.44	
		840	37.33	

TABLE 3 SPLIT TENSILE STRENGTH

% Fiber	Age (Days)	Load (kN)	SplitTensile Strength (N/Mm <sup>2</sup> )	Avg. Split Tensile Strength (N/Mm <sup>2</sup> )
0%	28	177.6	2.51	2.52
		184	2.60	
		172.8	2.44	
Mercerized fiber	28	196	2.77	2.84
		208	2.94	
		200	2.82	
		180	2.54	



Unmercerized fiber	28	192	2.71	2.67
		196	2.77	

**TABLE 4. FLEXURAL STRENGTH**

% Fiber	Age (Days)	Load(kN)	'a' incm	FlexuralStrength ( N/mm <sup>2</sup> )	Avg. Flexural Strength ( N/mm <sup>2</sup> )
0%	28	6.4	19	2.56	2.66
		7.2	18	2.88	
		6.4	20	2.56	
Mercerized fiber	28	9.6	16	3.84	.84
		8.8	15	3.52	
		10.4	18	4.16	
Unmercerized fiber	28	7.2	14	2.88	2.72
		6.4	16	2.76	
		6.4	15	2.76	

**C. Results**

**TABLE 5. COMPRESSIVE STRENGTH FOR 14 DAYS CURING**

Sample	Initial Crack Load kN	Ult Load kN	Max. Def. Centre mm	Flexural Strength N/mm <sup>2</sup>	Ave Ultimate Load kN	Ave Max. Def. Centre mm	Ave Flexural Strength N/Mm <sup>2</sup>
<b>CRCB</b>							
1	8.25	44.25	8.14	13.27	47.75	7.91	14.32
2	7.25	47.50	7.78	14.25			
3	12.75	51.50	7.82	15.45			
<b>MMFRCB</b>							
1	22.50	66.75	6.26	20.02	66.83	6.53	20.05
2	19.25	63.25	6.54	18.97			
3	26.50	70.50	6.81	21.15			
<b>UMFRCB</b>							
1	14.25	59.50	7.27	18.75	55.67	7.26	16.99
2	9.50	56.25	7.02	16.87			
3	17.50	51.25	7.48	15.37			

Sample

Copyright to IJARSCT  
[www.ijarsct.co.in](http://www.ijarsct.co.in)



DOI: 10.48175/IJARSCT-34814



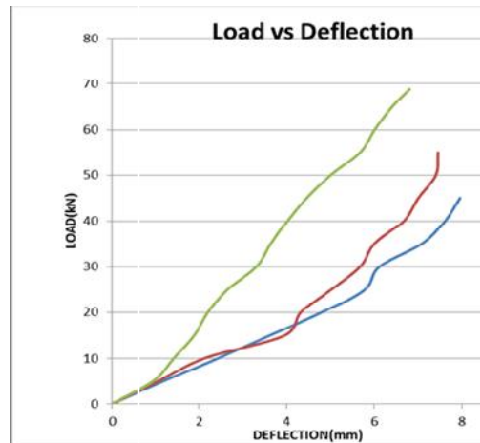

#### IV. CONCLUSION

- Due to the crack resistance and brittle resistance of fiber, the strength of concrete tends to increase.
- From the test results, it was found that as the volume of fiber increases, the strength parameters of concrete is also increased.
- The optimum fiber content for Maguey Fiber was 2% by the weight of cement
- The Compressive Strength, Split Tensile Strength and Flexural strength of 2% mercerized Palmyra Palm fiber Concrete occurs to be maximum on comparison with 2% unmercerized Maguey Fiber concrete and conventional Concrete.
- Strength Parameters like Compressive Strength upto 15.89% , Split Tensile Strength upto 12.69% and Flexural Strength upto 44.36% was obtained on Addition of 2% mercerized Maguey Fiber concrete on comparison with conventional concrete.
- It was observed that the 2% mercerized fibre reinforced concrete beams possess maximum flexural strength of 20.05MPa at increased percentage of 40.20 on comparison with Conventional Reinforced concrete beams, while 2% Unmercerized fibre reinforced concrete beams possess flexural strength of 16.99MPa.
- On comparison with CRCB,2%MMFRCB possess high moment carrying capacity and energy absorption capacity.
- On Average, maximum central deflection for CRCB is 7.91mm at 47.75kN, for the 2%MMFRCB is 6.53mm at 66.83 kN, for 2%UMFRCB is 7.26mm at 55.67kN.te.

#### REFERENCES

- [1] A.R, Santhakumar (2012) 'Concrete Technology', 10th Edition, Oxford Universty Press.
- [2] Mahyuddin Ramli And Eethar Thanoon Dawood (2010), ' Effects of Palm Fiber on the Mechanical Properties of Lightweight Concrete Crushed Brick', 2010 Science Publications.
- [3] Pratik Patel, Dr. Indrajit N. Patel(2013), 'A Literature Review on Use of Cellulose Fibres And Supplementary Material Silica Fume in Concrete' Volume: 2, Issue : 5, May (2013) .
- [4] IS 383 – 1970, 'Specification For Coarse And Fine Aggregates From Natural Sources For Concrete'.
- [5] IS 456 -2000 'Plain and Reinforced Concrete Code Of Practice'.
- [6] IS 1489(Part I)-1991, 'Portland Pozzolana Cement-Specification (Fly Ash Based)'.
- [7] IS 2386 (Part I) – 1963, 'Methods of Test for Aggregates For Concrete'.
- [8] IS 2386 (Part III) – 1963, 'Methods of Test for Aggregates For Concrete'.
- [9] IS10262 – 1982, 'Recommended Guidelines For Concrete Mix Design'.
- [10] Shetty, M.S (2003) 'Concrete Technology – Theory and Practice', 5th Edition, S.Chand & Company Ltd.



- [11] Tara Sen, H. N. Jagannatha Reddy (2011), 'Application of Sisal, Bamboo, Coir and Jute Natural Composites in Structural Upgradation', Vol.2, No.3, June (2011).
- [12] Z. Ahmad, H.M. Saman and P.M. Tahir (2010), 'Oil Palm Trunk Fiber as A Bio-Waste Resource For Concrete Reinforcement', IJMME, Vol.5 (2010)

