

GSM-Based Supervisory Control System Using Solar Panels & Battery Management System (BMS)

Raghuvendra Kumar¹, Manish Prasad², Kamaran Ansari³, Rajneesh Kumar Gupta⁴, Gaurav Gupta⁵

B. Tech Students, Department of Electrical Engineering¹⁻⁴

Assistant Professor, Department of Electrical Engineering⁵

R.R. Institute of Modern Technology, Lucknow, India

Abstract: *This paper presents a comprehensive design, development, and analysis of a GSM-based supervisory control system integrated with a solar photovoltaic (PV) system and Battery Management System (BMS). The proposed system ensures efficient renewable energy utilization with real-time monitoring, and remote control via GSM communication. Detailed modeling, simulation, hardware implementation, and performance evaluation are included to validate the effectiveness of the system.*

Keywords: solar photovoltaic

I. INTRODUCTION

Renewable energy systems, especially solar PV systems, are rapidly gaining importance due to environmental concerns and increasing energy demand. However, lack of monitoring and improper battery usage often reduce system efficiency.

To overcome these issues, this research proposes a GSM-based supervisory control system. The system enables remote monitoring, fault detection, and control, making it suitable for rural and off-grid areas.

II. METHODOLOGY

The methodology of the proposed GSM-based supervisory control system using Solar Panel and BMS is divided into design, modeling, implementation, and testing phases to ensure a systematic and reliable approach.

2.1 System Design Approach

The system is designed using a modular approach consisting of-

- Solar energy generation unit
- Energy storage and protection unit (Battery + BMS)
- Data acquisition unit (Sensors)
- Control unit (Microcontroller)
- Communication unit (GSM module)

Each module is integrated to achieve real-time monitoring and control.

2.2 Hardware Implementation

This step involves material and component selection, hardware installation, and prototype design. This project consists of using several electrical and electronics components. The main components are Arduino IDE, ATMEGA328, GPRS Technology, GSM Technology, IR Sensor, OPAMP, Relay, Relay Driver ULN2803, Solar Panel, BMS etc.



2.2.1 Arduino IDE (Integrated Development Environment)

Arduino is a tool for making computers that can sense and control more of the physical world than your desktop computer. It's an open-source physical computing platform based on a simple microcontroller board, and a development environment for writing software for the board.

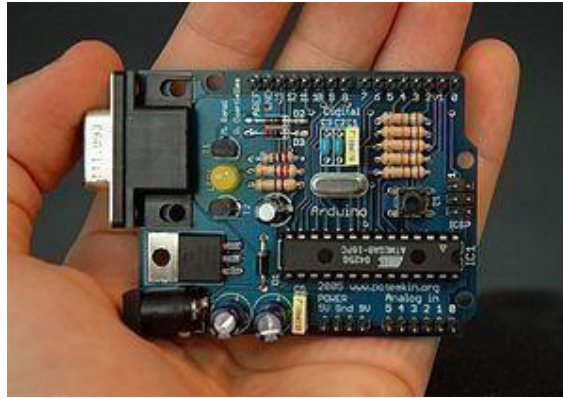

Fig.1: Arduino IDE

2.2.2 ATMEGA328

ATMEGA328 is a microcontroller used in Arduino boards for processing input signals and controlling output devices.



Fig.2: ATMEGA328

2.2.3 GPRS Technology

The General Packet Radio Service (GPRS) is a new service that provides actual packet radio access for Global System for Mobile Communications (GSM) and Time-Division Multiple Access (TDMA) users. It provides for the transmission of IP packets over existing cellular networks, bringing the Internet to the mobile phone.

2.2.4 GSM Technology

GSM (Global System for Mobile Communication) is a digital cellular communication technology widely used for transmitting voice and data services. It operates using a network of base stations and enables wireless communication over long distances.



Fig.3: GSM Technology



2.2.5 IR Sensors

IR sensors are used for detecting obstacles or environmental conditions in the system. Infrared (IR) light is electromagnetic radiation with longer wavelengths than those of visible light, extending from the nominal red edge of the visible spectrum at 0.74 micrometers (μm) to 300 μm .

2.2.6 OPAMP

An operational amplifier (op-amp) is a DC-coupled high-gain electronic voltage amplifier with a differential input and, usually, a single-ended output. An op-amp produces an output voltage that is typically hundreds of thousands of times larger than the voltage difference between its input terminals.

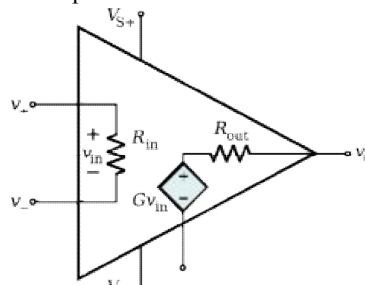

Fig.4: OPAMP

2.2.7 Relay

Relays are electromechanical switches. Relays are used to control high-power devices using low-power signals from the microcontroller. Relays which come in assorted sizes, ratings, and applications, are used as remote control switches that are controlled by another switch, such as a horn switch or a computer as in power train control module.



Fig.5: Relay

2.2.8 Relay Driver ULN2803

The eight NPN Darlington connected transistors in this family of arrays are ideally suited for interfacing between low logic level digital circuitry (such as TTL, CMOS or PMOS/NMOS) and the higher current/voltage requirements of lamps, relays, printer hammers or other similar loads for a broad range of computer, industrial, and consumer applications.

2.2.9 Solar Panel

A 12V 10W solar panel is ideal for small-scale, low-power projects, especially where renewable and remote power solutions are required.





Fig.6: Solar Panel

2.2.10 BMS

BMS is an electronic system that manages and protects a rechargeable battery. It ensures the battery operates safely, efficiently, and for a longer life.

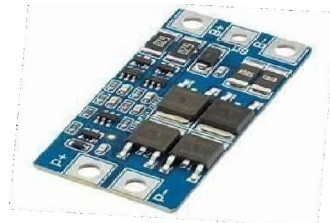

Fig.7: BMS

2.3 Research Design

The research design for the proposed GSM-based supervisory control system using Solar Panel and BMS follows an experimental and applied research approach. The aim is to design, develop, and evaluate a real-time energy monitoring and control system that can operate efficiently in remote and off-grid environments.

This study combines both hardware implementation and analytical evaluation to ensure that the system is not only theoretically sound but also practically feasible.

2.4 Block Diagram of The Project

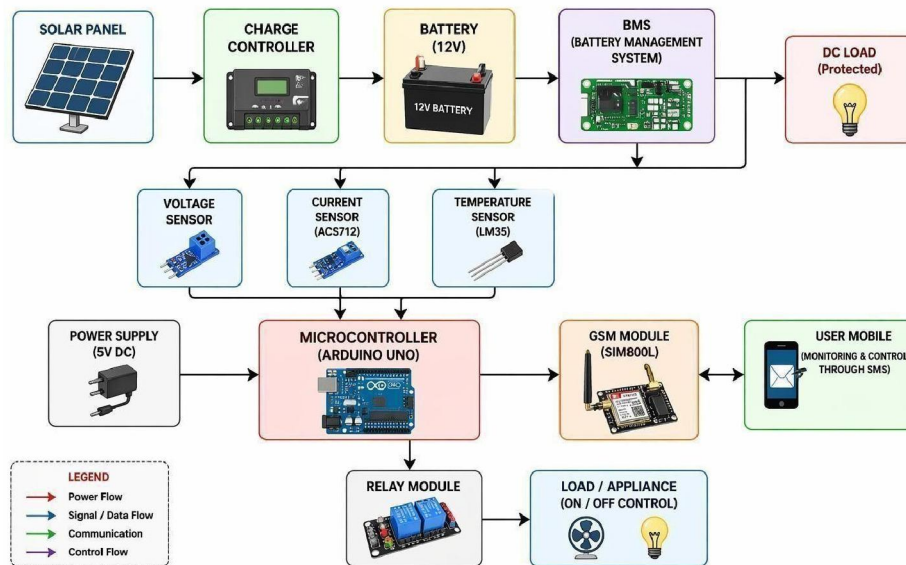

Fig.8: Block Diagram of Project



2.5 Literature Review

Various studies have focused on IoT-based monitoring systems. However, GSM-based systems are more reliable in low-network areas. Research also shows that BMS significantly improves battery life and safety.

2.6 Components Description

Solar Panel: Converts sunlight into electrical energy.

Battery: Stores generated energy.

BMS: Protects battery from overcharge, over-discharge, and overheating.

Microcontroller: Controls entire system.

GSM Module: Sends/receives SMS for remote control.

2.7 Working Principle

The system works by converting solar energy into electrical energy and storing it in a battery. The BMS ensures safe operation. Sensors send real-time data to the microcontroller, which communicates via GSM.

2.8 Software Implementation

- Arduino IDE for programming
- Embedded C language
- GSM AT Commands for communication

2.9 Advantages

- Remote monitoring
- Improved battery life
- Low cost

2.10 Applications

- Solar plants
- Rural electrification
- Smart homes

III. PROJECT MODEL

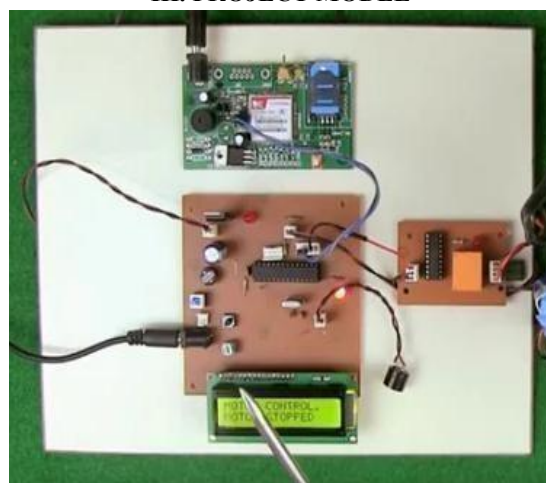

Fig.9: Project Model of GSM Based Supervisory Control System



IV. RESULT, CONCLUSION & FUTURE SCOPE

4.1 Result

The project titled “GSM Based Supervisory Control System Using Solar Panel and BMS” was successfully designed and implemented. The system effectively integrates solar energy generation with a Battery Management System (BMS) and GSM communication for remote monitoring and control.

The solar panel was able to generate sufficient power under standard environmental conditions, which was efficiently stored and managed using the BMS. The BMS ensured proper battery charging, prevented overcharging and deep discharge, and maintained overall battery health. The GSM module enabled reliable wireless communication, allowing real-time monitoring of system parameters such as battery voltage, current, and charging status. Alerts and updates were successfully transmitted to the user via mobile communication, ensuring timely supervision and control.

4.2 Conclusion

- The proposed system improves solar energy management using GSM and BMS integration.
- GSM technology provides remote accessibility, allowing users to monitor and control the system through SMS without internet.
- The system is cost-effective and easy to implement, making it practical for real-world applications.
- Overall, the proposed system provides a reliable, safe, and intelligent solution for solar energy monitoring and control.

4.3 Future Scope

- IoT integration.
- AI-based fault detection.
- Mobile app development.

REFERENCES

- [1]. M. H. Rashid, Power Electronics: Circuits, Devices and Applications, 3rd ed., Pearson Education, 2004.
- [2]. S. P. Bansal, Renewable Energy Sources and Applications, New Delhi: Tata McGrawHill, 2005.
- [3]. V. K. Mehta and R. Mehta, Principles of Electronics, New Delhi: S. Chand Publishing, 2010.
- [4]. “ATMEGA328P Microcontroller Datasheet,” Microchip Technology.
- [5]. “GSM Based Remote Monitoring and Control System,” IEEE Xplore Digital Library, Available: <https://ieeexplore.ieee.org>
- [6]. IEEE Papers on Solar Monitoring.
- [7]. GSM Module Datasheet.
- [8]. Arduino Documentation.
- [9]. A.S. Sedra and K. C. Smith, Microelectronic Circuits, 7th ed., Oxford University Press, 2015.

