

Implementation of Wireless Power Transfer in Solar Assisted EV-to-EV Charging System

Ajay Prasad¹, Akhilesh Singh², Aman Yadav³, Ankur Sharma⁴, Mahtabul Haque⁵

B. Tech Students, Department of Electrical Engineering¹²³⁴

Assistant Professor, Department of Electrical Engineering⁵

R. R. Institute of Modern Technology, Lucknow, India

Abstract: *The fast growth of electric vehicle (EV) technology requires new and adaptable charging solutions to address the challenges of traditional grid -dependent systems. This paper introduces an innovative solar-assisted wireless EV-to-EV charging system that allows energy transfer between electric vehicles without physical connections. The system combines renewable energy generation, smart battery monitoring, and wireless power transfer (WPT) into a single framework for efficient and sustainable energy sharing. The setup has two main components: a source EV, which includes a solar panel, energy storage system, and real-time battery monitoring unit, and a receiver EV, which is built to wirelessly receive and store energy. It uses inductive coupling-based wireless power transfer. In this process, high-frequency alternating current in the transmitter coil creates a magnetic field that induces voltage in the receiver coil.*

A battery monitoring system based on a microcontroller provides real-time details on voltage levels and state-of-charge (SoC), ensuring effective energy management and safe operation. The addition of solar energy makes the system more sustainable by reducing reliance on outside charging options and allowing energy collection during downtime or while driving. The model is examined under different operating conditions, such as energy transfer efficiency, coil alignment sensitivity, and load changes. Experimental results show that the system offers a dependable and flexible solution for emergency charging situations, greatly enhancing energy access and mobility.

This research offers a scalable and environmentally friendly way to approach decentralized EV charging. It supports the creation of next-generation smart transportation systems and sustainable energy networks...

Keywords: Wireless Power Transfer, Electric Vehicle, Solar Energy, EV-to-EV Charging, Inductive Coupling, Battery Monitoring System

I. INTRODUCTION

The global shift towards sustainable transportation has greatly accelerated the use of electric vehicles (EVs). This change is largely driven by the urgent need to cut greenhouse gas emissions and reduce reliance on fossil fuels. However, the widespread use of EVs still faces major challenges, including limited charging infrastructure, long charging times, and range anxiety. Conventional plug -in charging systems are effective but lack flexibility and depend heavily on fixed grid -based stations, making them less suited for real-time energy needs. To overcome these challenges, new technologies like wireless power transfer (WPT) and renewable energy integration have attracted significant attention in recent years. Wireless charging removes the need for physical connectors, providing greater convenience, safety, and automation. At the same time, incorporating solar energy into EV systems offers a sustainable and decentralized energy source, allowing vehicles to produce and use clean energy on their own. In this context, this paper suggests a solar-assisted wireless EV-to-EV (vehicle-to-vehicle) charging system. This system shifts away from traditional one-way charging models towards a cooperative and decentralized energy-sharing approach. It allows one



electric vehicle, called the source EV, to wirelessly transfer energy to another vehicle, known as the receiver or discharging EV. This capability is especially useful in emergencies, remote areas, or where conventional charging infrastructure isn't available. The system architecture includes several components: a photovoltaic energy generation unit, an energy storage system, a wireless power transmission module using inductive coupling, and a real-time battery monitoring system. The source EV features solar panels and a battery management interface that tracks voltage and state-of-charge (SoC). This information is crucial for effective energy use. The wireless transmission mechanism uses high-frequency electromagnetic fields to enable contactless energy transfer between aligned coils of the two vehicles. Moreover, the proposed system focuses on portability, scalability, and environmental sustainability. By allowing peer-to-peer energy transfer between EVs, it reduces dependence on centralized charging infrastructure and encourages a more resilient and adaptable energy ecosystem. The integration of monitoring and control systems ensures operational safety, efficiency, and user awareness. This research aims to support the development of next-generation intelligent transportation systems by presenting a flexible, eco-friendly, and user-friendly charging solution. This framework not only improves the practicality of EV adoption but also supports the broader vision of smart energy networks and sustainable transportation.

II. OBJECTIVES

The main goal of this project is to design and implement a solar-assisted wireless EV-to-EV charging system. This system will allow efficient and reliable energy transfer through inductive coupling between the transmitting and receiving coils. It focuses on transferring electrical energy wirelessly from a source electric vehicle, which has a solar panel and energy storage system, to another electric vehicle that needs charging, without any physical connectors. The system will use renewable solar energy to charge the battery of the source vehicle. This battery will then be used for wireless power transmission. This approach reduces dependency on traditional grid-based charging stations and promotes the use of clean, sustainable energy. The inductive coupling mechanism creates a high-frequency alternating magnetic field in the transmitting coil, which induces voltage in the receiving coil of the second vehicle, enabling contactless energy transfer. Additionally, the project includes a microcontroller-based battery monitoring system. This system continuously measures and displays battery voltage and state of charge, ensuring efficient energy management and safe operation. The overall goal is to create a flexible, portable, and user-friendly charging solution that can be used in emergencies, remote locations, or areas with limited charging options..

III. METHODOLOGY

3.1. HARDWARE IMPLEMENTATION

This step involves material and component selection, hardware installation, and prototyping design. This project consists of using several electronic components. The main components used are:

3.1.1. SOLAR PANEL

A 12V, 10W solar panel is a device that turns solar energy into electrical energy using the Photovoltaic effect. It consists of several solar cells, usually made from semiconductor materials like silicon, which are linked together to produce the needed voltage and current. The panel has a glass cover for protection and a frame for support, and it includes a junction box for electrical connections.

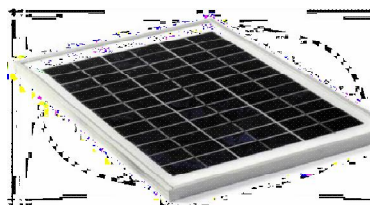

Fig 1. Solar Panel



3.1.2. BATTERY MONITORING SYSTEM

The battery monitoring system measures and shows key battery parameters like voltage and status in real time. This system helps keep operations safe by preventing overcharging or deep discharge and extends battery life. The hardware setup includes a microcontroller, a display unit, a voltage sensing circuit, and power supply components. In this system, appropriate circuitry senses the battery voltage and sends it to the microcontroller for processing. The microcontroller then displays the processed data on an LCD screen for users to monitor.

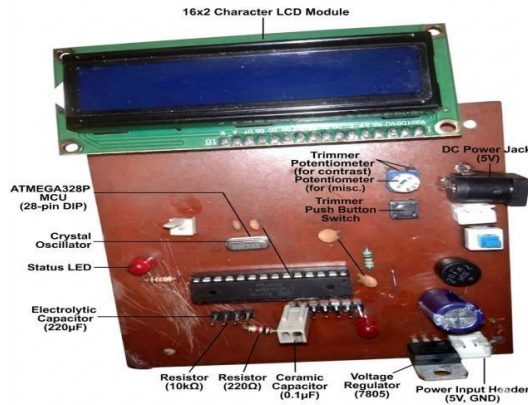

Fig 2. Battery Monitoring System

3.1.3. WIRELESS TRANSMITTER PANEL

The transmitter panel is the main unit responsible for generating and transmitting electrical energy wirelessly to the receiver system. It converts DC power (from battery/solar source) into high-frequency AC and creates a magnetic field through a transmitting coil for wireless power transfer.

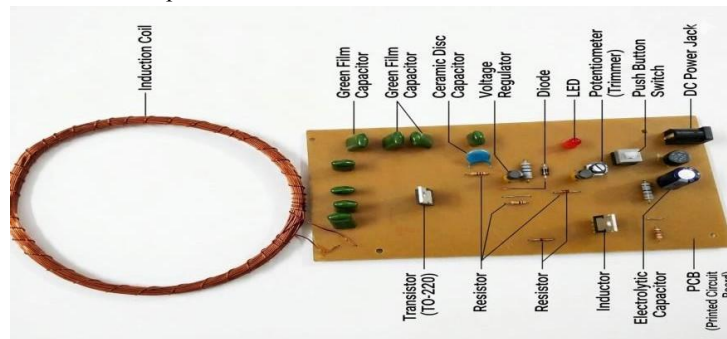

Fig 3. Wireless Transmitter Panel

3.1.4. WIRELESS RECEIVER PANEL

The receiver panel is the unit responsible for receiving wireless electrical energy from the transmitter system and converting it into usable electrical power. It captures the magnetic field generated by the transmitter coil and converts it into electrical energy to drive the load such LED.





Fig 4. Wireless Receiver Panel

3.1.5. 12V RECHARGEABLE BATTERY

A 12V rechargeable battery is an electrical energy storage device that can store and supply a nominal voltage of 12 volts and can be used multiple times by recharging it after discharge. Unlike disposable batteries, it can be charged again and again using an appropriate charger, making it cost-effective and environmentally friendly.



Fig 5. 12V Rechargeable Battery

3.1.6. DC GEARED MOTOR

A DC geared motor is used in the solar electric vehicle to provide the necessary motion for movement. It converts electrical energy from the battery into mechanical rotation, while the attached gearbox reduces the speed and increases the torque. This high torque at low speed helps the vehicle move smoothly and carry load efficiently. In this project, the DC geared motor plays an important role in driving the wheels of the solar EV and ensures controlled and stable movement.



Fig 6. DC Geared Motor

3.1.7. MOTOR CONTROL & DRIVE SYSTEM

A motor controller is an electronic circuit that controls the operation of an electric motor by regulating its speed, direction, and power supply. In this project, the motor controller receives control signals from the remote receiver and drives the motor accordingly, allowing functions such as forward, reverse, and stop of the electric vehicle.



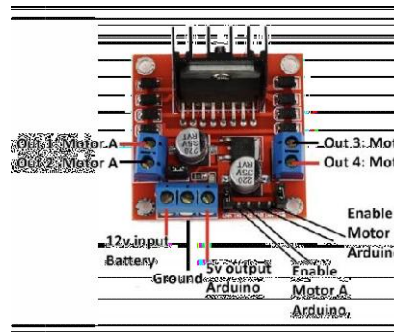

Fig 7. Motor Control & Drive System

3.2. SOFTWARE REQUIREMENTS

The software required for this project is the Arduino IDE, which is used to write, compile, and upload the program into the Arduino microcontroller. It provides a simple interface where code is written in C++ language and then converted into machine code using a built-in compiler. In this project, Arduino is used for battery monitoring. It plays an important role in measuring the battery voltage, processing the data and displaying the results on an LCD screen. The Arduino continuously monitors the battery condition and provides real-time information such as voltage level and charge percentage. This helps in understanding the battery status and ensures efficient operation of the system.

IV. APPROACH

When sunlight is available, the solar panel mounted on the electric vehicle generates electrical energy, typically around 12V DC under standard conditions. A charge controller regulates this voltage to ensure safe and stable charging of the battery. The energy is stored in a rechargeable battery, which serves as the main power source for the wireless transmission system. The stored DC energy in the battery is then used for wireless power transfer. Because inductive coupling needs alternating current, the DC supply is converted into high-frequency AC using an oscillator or inverter circuit. This alternating current powers the transmitting copper coil, creating a changing magnetic field around it. A voltage sensing circuit connects to the battery to continuously monitor voltage levels. This information is processed using a microcontroller like the Arduino UNO (or an ATmega-based controller) and displayed on a 16x2 LCD. The display shows real-time battery voltage and charging percentage, enabling efficient monitoring and control of the system. On the receiver side, a receiving coil is installed in the second electric vehicle. When this coil is placed within the magnetic field created by the transmitter coil, an electromotive force (EMF) is induced through inductive coupling. The induced voltage starts off as AC. This AC voltage is converted into DC using a bridge rectifier circuit. A filter capacitor smooths the output, and a voltage regulator ensures a stable DC supply for charging the battery of the receiving vehicle. The regulated output charges and stores energy in the receiver vehicle's battery. An indicator or display system shows the charging status and remaining battery level of the receiver vehicle. The overall system includes solar panels, batteries, oscillator circuits, transmitting and receiving coils, rectifiers, voltage regulators, microcontrollers, and display units to enable efficient wireless energy transfer. This system demonstrates a practical solar-powered wireless EV-to-EV charging method, removing the need for physical connections and supporting future advancements like portable and dynamic wireless charging systems.



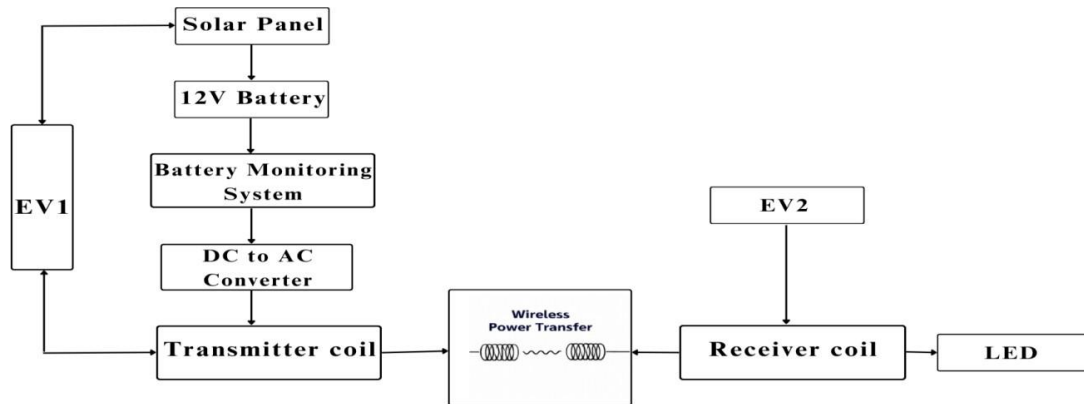

Fig 8: Block Diagram of Implement a solar-assisted wireless EV-to-EV charging system.

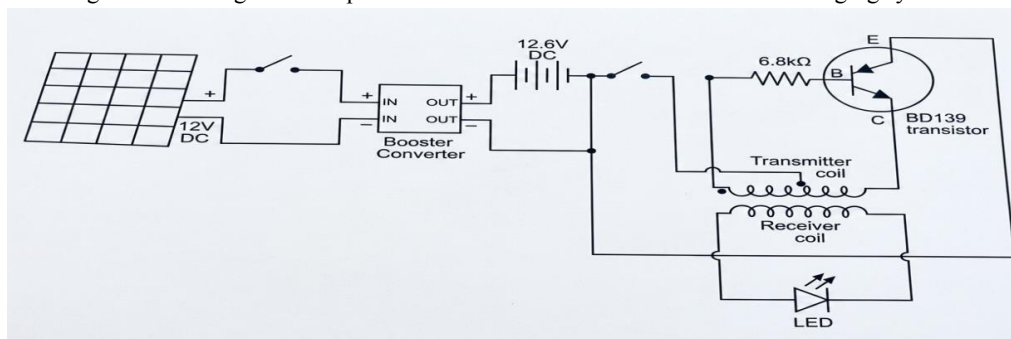

Fig 9: Circuit Diagram of Implement a solar-assisted wireless EV-to-EV charging system.

V. ADVANTAGES & APPLICATIONS

5.1. ADVANTAGES

- **Wireless Charging:** Enables contactless energy transfer, eliminating the need for physical cables and connectors.
- **Solar-Based System:** Utilizes renewable solar energy, making the system eco-friendly and reducing dependency on grid electricity.
- **EV-to-EV Charging:** Allows one electric vehicle to charge another, increasing flexibility and usability.
- **Convenient and User-Friendly:** Easy to operate without the need for plug-in charging infrastructure.
- **Low Maintenance:** Fewer mechanical connections result in reduced wear and tear.
- **Portable System:** Can be used anywhere, especially useful in remote or rural areas.
- **Supports Sustainable Development:** Promotes green energy and reduces carbon emissions.

5.2. APPLICATIONS

- **Emergency Roadside Assistance:** Useful when a vehicle runs out of charge in remote or isolated areas.
- **Smart Transportation Systems:** Can be integrated into future smart cities for advanced mobility solutions.
- **Autonomous Vehicles:** Supports self-charging features in driverless cars.
- **Public Transport Systems:** Applicable in electric buses and taxis for flexible charging.
- **Parking Area Charging:** Wireless charging in parking spaces without plug-in infrastructure.
- **Remote Area Power Supply:** Useful in rural or off-grid locations where charging stations are unavailable.



- Military Applications: Can be used for charging electric defense vehicles in the field.
- Research and Development: Useful for further advancements in wireless energy transfer and renewable integration.

VI. RESULT , FUTURE SCOPE & CONCLUSION

6.1. RESULT

The proposed solar-assisted wireless EV-to-EV charging system was designed and implemented to show that contactless energy transfer between two electric vehicles is possible. The system underwent testing under various conditions to measure its performance regarding energy transfer, efficiency, reliability, and practical usability. During experiments, the solar panel generated enough electrical energy in normal sunlight to charge the 12V battery effectively. The battery monitoring system displayed real-time voltage levels and showed the state-of-charge clearly through the LCD interface. This ensured proper energy management and confirmed the monitoring unit's reliability. The DC-to-AC converter changed stored DC power into high-frequency AC, which was provided to the transmitter coil. This setup produced a stable and consistent magnetic field around the transmitter coil, allowing for efficient wireless power transmission. On the receiver side, the receiver coil successfully captured the magnetic field and generated an induced voltage.

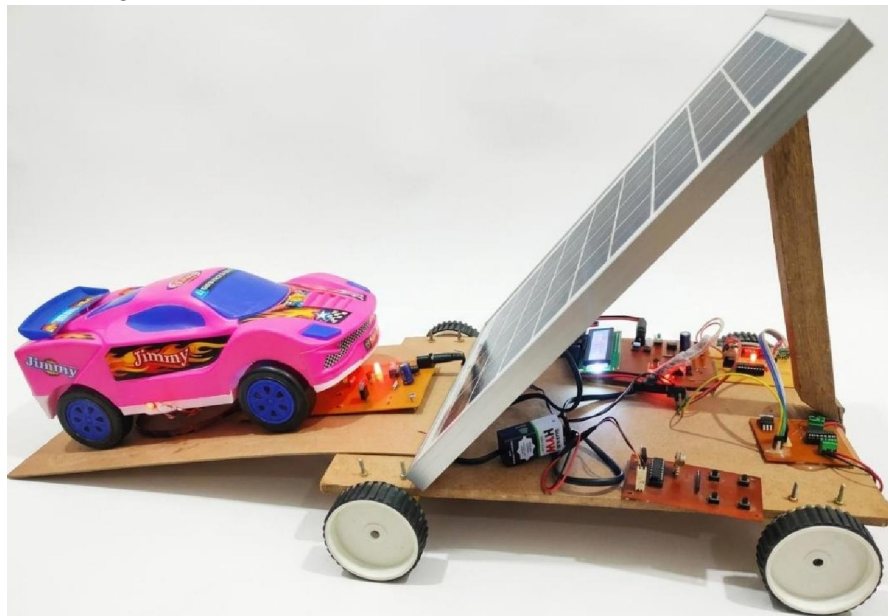

Fig 6.1. Result of Wireless Power Transfer in Solar Assisted EV to EV Charging System

6.2. FUTURE SCOPE

The proposed solar-assisted wireless EV-to-EV charging system presents a promising foundation for the development of advanced and intelligent electric vehicle charging technologies. Although the current system demonstrates the feasibility of short-range wireless energy transfer, there are several opportunities for enhancement and large-scale implementation in the future. One of the major areas of improvement lies in increasing the efficiency of wireless power transfer. This can be achieved by adopting advanced techniques such as resonant inductive coupling, improved coil design, and optimized operating frequencies. These enhancements can significantly increase the transfer distance and power capacity, making the system suitable for real-world electric vehicle charging applications. The system can



further be expanded to support direct battery-to-battery charging in electric vehicles by incorporating high-power converters and advanced battery management systems. This would enable practical EV-to-EV charging, allowing vehicles to share energy efficiently in real-time scenarios such as emergencies or long-distance travel.

6.3. CONCLUSION

This paper detailed the design and setup of a solar-assisted wireless EV-to-EV charging system. It offers a modern and sustainable answer to the challenges of traditional electric vehicle charging methods. The proposed system combines solar energy generation, battery storage, wireless power transfer, and real-time monitoring into a single framework. This allows for efficient and contactless energy sharing between two electric vehicles. The experimental results show that inductive coupling works well for short-range wireless energy transfer, with reliable performance when the coils are aligned properly and under the right conditions. Adding a solar panel makes the system more sustainable by using renewable energy. This approach reduces reliance on grid-based charging infrastructure. Furthermore, the battery monitoring system provides real-time information, which helps manage energy safely and efficiently. The system is particularly useful in emergencies, remote locations, and situations where conventional charging stations are not available. While the current setup faces limitations, such as transfer distance and efficiency, it lays a strong groundwork for future developments in wireless charging technology

REFERENCES

- [1]. Kurs, A. Karalis, R. Moffatt, J. D. Joannopoulos, P. Fisher, and M. Soljačić, “Wireless Power Transfer via Strongly Coupled Magnetic Resonances,” *Science*, vol. 317, no. 5834, pp. 83–86, 2007.
- [2]. S. Li and C. C. Mi, “Wireless Power Transfer for Electric Vehicle Applications,” *IEEE Journal of Emerging and Selected Topics in Power Electronics*, vol. 3, no. 1, pp. 4–17, Mar. 2015.
- [3]. L. Cannon, J. F. Hoburg, D. D. Stancil, and S. C. Goldstein, “Magnetic Resonant Coupling As a Potential Means for Wireless Power Transfer to Multiple Small Receivers,” *IEEE Transactions on Power Electronics*, vol. 24, no. 7, pp. 1819–1825, 2009.
- [4]. T. Rim and C. Mi, *Wireless Power Transfer for Electric Vehicles and Mobile Devices*, Hoboken, NJ, USA: Wiley-IEEE Press, 2017.
- [5]. J. M. Miller, O. C. Onar, and M. Chinthavali, “Primary-Side Power Flow Control of Wireless Power Transfer for Electric Vehicle Charging,” *IEEE Journal of Emerging and Selected Topics in Power Electronics*, vol. 3, no. 1, pp. 147–162, Mar. 2015.
- [6]. H. H. Wu, A. Gilchrist, K. Sealy, and D. Bronson, “A Review on Inductive Charging for Electric Vehicles,” *IEEE Transactions on Industrial Electronics*, vol. 59, no. 6, pp. 2550–2560, June 2012.
- [7]. N. Tesla, “Apparatus for Transmitting Electrical Energy,” U.S. Patent 1,119,732, Dec. 1, 1914.
- [8]. Y. Jang and M. M. Jovanović, “A Contactless Electrical Energy Transmission System for Portable-Phone Battery Chargers,” *IEEE Transactions on Industrial Electronics*, vol. 50, no. 3, pp. 520–527, June 2003.
- [9]. K. Fotopoulou and B. W. Flynn, “Wireless Power Transfer in Loosely Coupled Links: Coil Misalignment Model,” *IEEE Transactions on Magnetics*, vol. 47, no. 2, pp. 416–430, Feb. 2011.

