

Design & Development of E- Vehicle

Prof. Shejwal C. K.¹, Mr. Ahire Tushar Baliram², Mr. Aher Vishal Rajendra³,

Mr. Badwar Akshay Vijay⁴, Mr. Algat Satish Balu⁵

^{1,2,3,4,5} Department of Electrical Engineering

^{1,2,3,4,5} S.N.D. College of Engineering & Research Center, Nashik

¹chandrkant.cs77@gmail.com ²tusharah780@gmail.com, ³vishalaher13022004@gmail.com,

⁴akshaybadwar3@gmail.com ⁵satishalgat0@gmail.com

Abstract: *The development of electric vehicles has become an important solution to reduce environmental pollution and dependence on fossil fuels. This project focuses on the design and development of a solar-assisted electric vehicle system that operates using a 48V lithium-ion battery pack as the primary energy source. The system integrates key components such as solar panels, a charge controller, battery management system (BMS), motor controller, BLDC motor, regenerative braking mechanism, and a DC–DC converter for auxiliary loads. Solar panels convert sunlight into electrical energy, which is regulated by the charge controller and stored in the battery pack for vehicle operation. The motor controller regulates the power supplied to the BLDC motor according to throttle input, enabling controlled speed and torque for efficient vehicle movement. The regenerative braking system improves energy efficiency by converting kinetic energy into electrical energy and sending it back to the battery during braking conditions. In addition, the DC–DC converter steps down the battery voltage to supply power to auxiliary components such as headlights, indicators, and dashboard systems. Safety features including fuse protection, proper wiring, and BMS monitoring ensure reliable and secure system performance. The proposed electric vehicle system demonstrates an energy-efficient, eco-friendly, and sustainable transportation solution suitable for future mobility applications while minimizing energy loss and improving overall operational efficiency..*

Keywords: Electric Vehicle, Solar Panel, BLDC Motor, Battery Management System, Regenerative Braking, Motor Controller, Lithium-ion Battery, Renewable Energy, Sustainable Transportation

I. INTRODUCTION

The rapid growth of transportation systems has significantly increased global energy consumption and environmental pollution. Conventional vehicles powered by internal combustion engines depend heavily on fossil fuels such as petrol and diesel, which release harmful greenhouse gases and contribute to air pollution and climate change. These environmental concerns have encouraged researchers and engineers to explore cleaner and more sustainable alternatives for transportation. Electric vehicles (EVs) have emerged as a promising solution because they operate using electrical energy instead of fossil fuels, thereby reducing carbon emissions and improving overall energy efficiency [1]. Electric vehicles use electric motors powered by rechargeable battery systems to provide propulsion. Unlike traditional vehicles, EVs eliminate the need for complex mechanical components such as fuel injectors, exhaust systems, and multi-stage transmissions. This simplified design reduces maintenance requirements and improves reliability. Moreover, electric motors provide instant torque and smooth acceleration, which enhances the driving experience and efficiency of the vehicle [2].

In recent years, the integration of renewable energy sources with electric vehicles has gained significant attention. Solar energy, in particular, is considered one of the most abundant and clean energy sources available. Solar panels can convert sunlight directly into electrical energy using photovoltaic technology. When integrated into an electric vehicle



system, solar panels can contribute to battery charging, thereby reducing dependence on grid electricity and improving the sustainability of the transportation system [3].

A key component of an electric vehicle is the battery pack, which stores electrical energy required for vehicle operation. Lithium-ion batteries are widely used in modern EVs due to their high energy density, longer life cycle, and lightweight properties. These batteries provide reliable power output and support efficient energy storage for electric propulsion systems. However, proper monitoring and protection of battery cells are necessary to ensure safety and performance [4].

To maintain safe battery operation, a Battery Management System (BMS) is employed. The BMS continuously monitors battery parameters such as voltage, temperature, and current, ensuring that the battery operates within safe limits. It prevents conditions like overcharging, deep discharging, and overheating, which could otherwise damage the battery or reduce its lifespan. In addition, the BMS helps balance individual battery cells, ensuring uniform performance and improving overall system efficiency [5].

The motor controller is another essential component of an electric vehicle. It acts as the control unit that regulates the flow of electrical energy from the battery to the electric motor. The controller converts the direct current (DC) from the battery into controlled electrical signals suitable for the motor. It also receives input from the throttle or accelerator and adjusts the motor speed and torque accordingly, allowing the driver to control vehicle acceleration and movement smoothly [6].

Most modern electric vehicles utilize Brushless DC (BLDC) motors because of their high efficiency, compact design, and low maintenance requirements. BLDC motors operate without brushes, which reduces friction losses and improves durability. These motors convert electrical energy into mechanical energy that rotates the wheels of the vehicle. Their high efficiency makes them suitable for applications where energy conservation and performance are critical [7].

Considering the increasing demand for clean energy transportation, the development of solar-assisted electric vehicles has become an important area of research. Integrating solar energy with battery-powered vehicles can enhance energy efficiency and reduce dependence on conventional energy sources. Therefore, the development of an electric vehicle with solar charging capability, efficient battery management, regenerative braking, and reliable motor control provides a sustainable and environmentally friendly transportation solution for the future [10].

II. PROBLEM STATEMENT

The increasing use of conventional vehicles powered by fossil fuels has led to serious environmental problems such as air pollution, greenhouse gas emissions, and depletion of non-renewable energy resources. Rising fuel costs and the growing demand for sustainable transportation have highlighted the need for alternative energy-based mobility solutions. Traditional vehicles also suffer from low energy efficiency and high maintenance requirements due to complex mechanical systems. Therefore, there is a need to develop an efficient and eco-friendly transportation system that reduces dependence on fossil fuels while utilizing renewable energy sources. The problem addressed in this project is the design and development of an electric vehicle system that efficiently uses a rechargeable battery pack integrated with solar energy support, regenerative braking, and a reliable motor control system to provide sustainable, energy-efficient, and environmentally friendly transportation.

III. OBJECTIVE

- To design a lightweight and aerodynamic vehicle structure that improves energy efficiency and enhances overall performance.
- To select and integrate an efficient electric motor, controller, and battery system suitable for reliable urban transportation.
- To develop a battery management system that ensures safe charging, discharging, and monitoring of battery health.
- To improve energy efficiency by optimizing power usage and implementing regenerative braking technology.



- To reduce environmental impact by replacing fossil fuel dependency with clean and sustainable electric energy.
- To evaluate vehicle performance based on parameters such as speed, acceleration, range, and charging efficiency.
- To develop a cost-effective electric vehicle prototype suitable for practical use and future large-scale production.

IV. LITERATURE SURVEY

1. Paper Title: Design and Development of Solar Powered Electric Vehicle

Authors: R. K. Sharma, P. Singh, and A. Kumar

Year: 2023

Publication: International Journal of Electrical and Computer Engineering

This paper focuses on the design and implementation of a solar-powered electric vehicle that integrates photovoltaic panels with a lithium-ion battery system. The authors developed a system where solar panels generate electrical energy that is stored in the battery and used to power an electric motor. A charge controller was used to regulate the charging process and prevent battery damage. The study also analyzed energy efficiency and charging performance under different sunlight conditions. The results showed that integrating solar panels with electric vehicles can significantly reduce dependency on grid electricity and improve overall sustainability.

2. Paper Title: Performance Analysis of BLDC Motor for Electric Vehicle Applications

Authors: S. Patel, M. Shah, and D. Mehta

Year: 2022

Publication: IEEE Access

This research paper analyzes the performance characteristics of Brushless DC (BLDC) motors used in electric vehicles. The authors studied parameters such as torque, speed control, efficiency, and power consumption. A simulation model was developed to evaluate the motor under different load conditions. The results demonstrated that BLDC motors provide high efficiency, low maintenance requirements, and improved performance compared to conventional brushed motors. The study concludes that BLDC motors are highly suitable for electric vehicle propulsion systems.

3. Paper Title: Battery Management System for Electric Vehicles: A Review

Authors: L. Wang, J. Li, and H. Zhang

Year: 2024

Publication: Renewable and Sustainable Energy Reviews

This paper presents a comprehensive review of battery management systems used in electric vehicles. The authors discuss various techniques for monitoring battery voltage, temperature, and current to ensure safe operation. The study highlights the importance of cell balancing, thermal management, and fault detection in lithium-ion battery packs. It also compares different BMS architectures and their effectiveness in improving battery performance and lifespan. The research emphasizes that an efficient BMS is essential for enhancing safety and reliability in electric vehicle systems.

4. Paper Title: Regenerative Braking System in Electric Vehicles: Design and Efficiency Analysis

Authors: K. Gupta and A. Verma

Year: 2023

Publication: Journal of Energy Storage

This paper investigates the role of regenerative braking systems in improving the energy efficiency of electric vehicles. The authors developed a model in which the electric motor operates as a generator during braking conditions to recover



kinetic energy. The recovered energy is stored back in the battery, which increases the driving range of the vehicle. Experimental results showed that regenerative braking can recover a significant percentage of the energy that would otherwise be lost as heat during braking.

5. Paper Title: Solar Integrated Electric Vehicle Charging System

Authors: M. Rahman, T. Islam, and S. Hossain

Year: 2022

Publication: Energy Reports

This research presents the development of a solar-integrated charging system for electric vehicles. The system includes photovoltaic panels, a charge controller, and an energy storage unit to supply power to EV batteries. The authors analyzed the efficiency of solar charging compared to conventional grid-based charging systems. The results indicated that solar charging can significantly reduce energy costs and carbon emissions, making it a promising solution for sustainable transportation.

6. Paper Title: Design and Development of a Low-Cost Electric Vehicle Prototype

Authors: A. Singh, V. Kumar, and R. Mishra

Year: 2024

Publication: International Journal of Automotive Technology

This paper describes the design and fabrication of a low-cost electric vehicle prototype aimed at urban transportation. The system includes a lithium-ion battery pack, motor controller, BLDC motor, and regenerative braking system. The authors conducted performance tests such as speed, acceleration, and energy consumption. The experimental results showed that the developed prototype achieved efficient power utilization and satisfactory driving range while maintaining low production cost. The study highlights the feasibility of developing affordable electric vehicles for developing countries.

V. PROPOSED SYSTEM

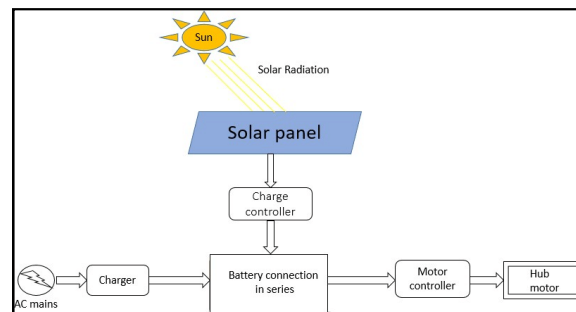

Fig 1: Proposed system

The proposed system focuses on the development of an efficient and environmentally friendly electric vehicle powered by a lithium-ion battery and supported by solar energy integration. The system is designed to provide reliable vehicle propulsion, improved energy efficiency, and reduced environmental impact compared to conventional fuel-based vehicles. The proposed model integrates several important components including solar panels, a charge controller, a battery pack with a battery management system, a motor controller, a BLDC motor, regenerative braking, and a DC–DC converter. These components work together to generate, store, control, and utilize electrical energy effectively for vehicle operation. The system ensures safe battery operation, smooth motor control, and efficient power distribution to both propulsion and auxiliary components.



A. Solar Energy Generation System

The proposed electric vehicle incorporates a solar panel to utilize renewable energy for battery charging. The solar panel consists of photovoltaic cells that convert sunlight directly into electrical energy through the photovoltaic effect. When sunlight falls on the panel, it generates direct current (DC) electricity which can be used to charge the vehicle battery. The integration of solar energy reduces dependence on external charging infrastructure and contributes to sustainable transportation. Solar charging also helps extend the operational range of the vehicle by continuously supplying additional energy during daylight conditions.

B. Charge Controller

The charge controller is responsible for regulating the electrical power generated from the solar panel before it is supplied to the battery. Solar panels may produce varying voltage levels depending on sunlight intensity, which can damage the battery if directly connected. The charge controller stabilizes voltage and current levels to ensure safe charging conditions. It prevents overcharging of the battery and improves battery efficiency by controlling the charging process. This component plays a vital role in maintaining the health and longevity of the battery pack.

C. Battery Pack and Battery Management System (BMS)

The battery pack acts as the main energy storage unit of the electric vehicle. In the proposed system, a 48V lithium-ion battery pack with sufficient capacity is used to store electrical energy generated from solar panels or external charging sources. Lithium-ion batteries are selected because of their high energy density, lightweight nature, and longer operational life.

The Battery Management System (BMS) is integrated with the battery pack to monitor and control various battery parameters such as voltage, temperature, and current. The BMS protects the battery from overcharging, over-discharging, and short-circuit conditions. It also balances the individual battery cells to ensure uniform charging and discharging, thereby improving the overall performance and lifespan of the battery.

D. Motor Controller

The motor controller functions as the central control unit of the electric vehicle propulsion system. It receives DC power from the battery and converts it into controlled electrical signals required to operate the motor. The controller also receives input from the throttle or accelerator, which determines how much power should be delivered to the motor.

By adjusting voltage and current levels, the controller regulates motor speed and torque according to driver input. This allows smooth acceleration, controlled speed variation, and efficient power utilization. The motor controller also supports regenerative braking functionality, enabling energy recovery during braking conditions.

E. BLDC Motor Drive System

The Brushless DC (BLDC) motor is used as the main propulsion unit of the electric vehicle. BLDC motors are preferred because they provide high efficiency, compact size, low maintenance, and reduced noise compared to conventional brushed motors. The motor converts electrical energy supplied from the controller into mechanical rotational energy.

This rotational energy is transmitted to the wheels of the vehicle, enabling forward motion. The efficiency of the BLDC motor contributes significantly to the overall performance of the electric vehicle by minimizing energy losses during operation.

F. Regenerative Braking System

The regenerative braking system is an important feature of the proposed electric vehicle. In traditional braking systems, kinetic energy is lost as heat when brakes are applied. However, in regenerative braking, the BLDC motor operates as a generator when the vehicle slows down or when the driver releases the throttle.

During this process, the motor converts kinetic energy into electrical energy, which is then sent back to the battery through the motor controller. This recovered energy improves the overall energy efficiency of the vehicle and increases the driving range by reducing energy wastage.



G. DC–DC Converter and Auxiliary Systems

The electric vehicle also includes several auxiliary components such as headlights, indicators, horn, dashboard instruments, and control electronics. These devices require lower voltage levels compared to the main propulsion system. Therefore, a DC–DC converter is used to step down the battery voltage from 48V to 12V.

This ensures that auxiliary systems receive the appropriate voltage for safe and reliable operation. The converter maintains stable voltage output and prevents overload on the main battery system.

H. Safety and Protection Mechanisms

Safety is a critical aspect of electric vehicle design. The proposed system includes protective components such as main fuses, proper wiring connections, and grounding through the vehicle chassis. A pre-charge resistor may also be included to prevent sudden current surges when the system is powered on. These safety mechanisms protect electrical components from faults and ensure reliable operation of the entire system.

Overall, the proposed system integrates renewable energy generation, efficient energy storage, intelligent motor control, and regenerative energy recovery to develop a sustainable electric vehicle solution. The system is designed to provide improved efficiency, reduced environmental impact, and reliable performance for future transportation applications.

VI. SYSTEM DESIGN

The diagram represents the working architecture of a solar-assisted electric vehicle system. It shows how energy flows from sunlight to the solar panel, then to the battery, and finally to the motor that drives the vehicle wheels. The system also includes an optional regenerative braking mechanism that helps recover energy during braking. Each component plays a specific role in generating, storing, controlling, and utilizing electrical energy for vehicle propulsion. The following sections explain each component separately.

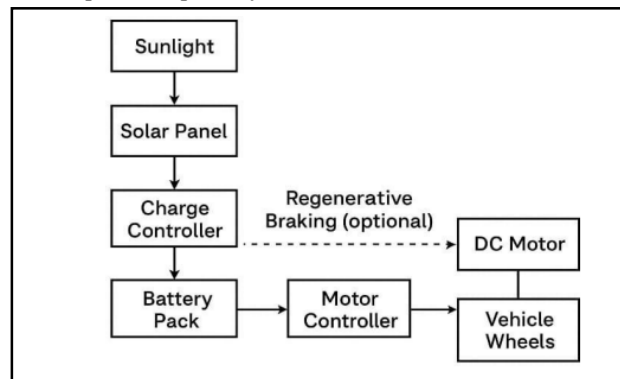

Fig 2: System Architecture

Sunlight

Sunlight acts as the primary renewable energy source for the system. Solar radiation contains energy that can be converted into electrical power using photovoltaic technology. In this system, sunlight falls on the solar panel, initiating the energy conversion process. Using solar energy helps reduce dependency on conventional electricity sources and makes the vehicle more environmentally friendly.



Solar Panel

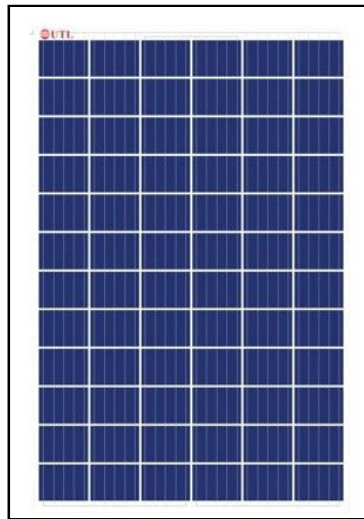

Fig 3: Solar panel

The solar panel is responsible for converting solar energy into electrical energy. It consists of photovoltaic (PV) cells made from semiconductor materials such as silicon. When sunlight strikes these cells, electrons begin to move, generating direct current (DC) electricity. The amount of electricity produced depends on sunlight intensity, panel efficiency, and surface area. The generated electrical power is then sent to the charge controller for proper regulation.

Charge Controller

The charge controller regulates the voltage and current produced by the solar panel before it reaches the battery pack. Solar panels may produce fluctuating voltage depending on sunlight conditions. If the battery is charged directly from the panel, it may lead to overcharging or battery damage. The charge controller prevents these problems by stabilizing the charging voltage and ensuring that the battery receives the correct amount of power.

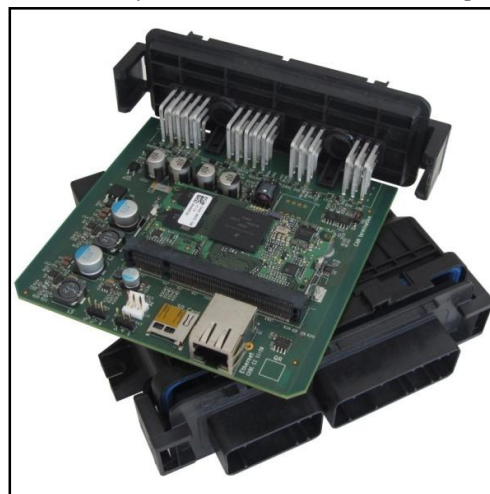

Fig 4: Charge controller

It also improves charging efficiency and extends battery life.



Battery Pack



Fig 5: Battery pack

The battery pack functions as the main energy storage unit of the electric vehicle. Electrical energy generated by the solar panel is stored in the battery for later use. In many electric vehicle systems, lithium-ion batteries are used because they offer high energy density, long lifespan, and lightweight properties. The stored energy in the battery supplies power to the motor controller and other vehicle components during operation.

Motor Controller

The motor controller acts as the control unit of the propulsion system. It receives electrical energy from the battery pack and regulates how much power should be delivered to the motor. The controller also processes input from the accelerator or throttle to determine the required motor speed and torque.

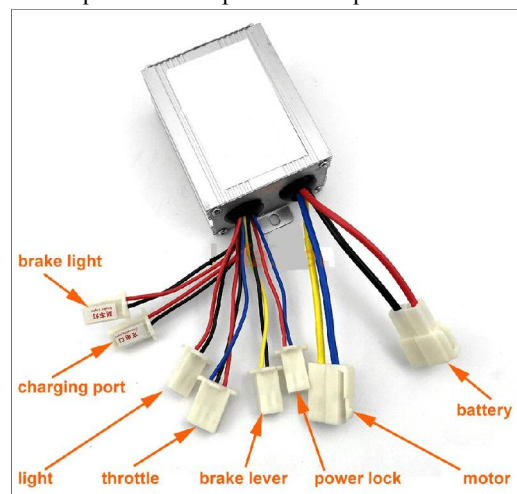

Fig 5: Motor controller

By controlling voltage and current supplied to the motor, the controller ensures smooth acceleration, efficient power use, and stable vehicle operation.



DC Motor

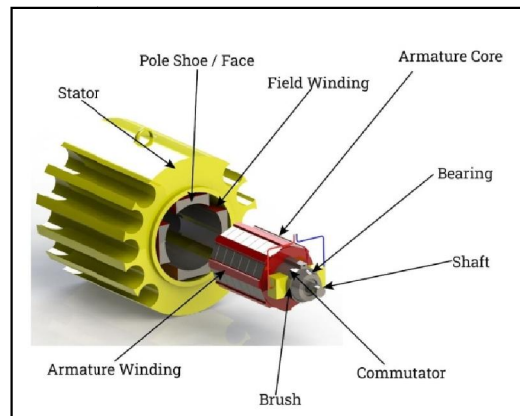

Fig 6: DC motor

The DC motor is responsible for converting electrical energy into mechanical energy. When electrical power is supplied to the motor, it produces rotational motion through electromagnetic interaction. The rotating shaft of the motor generates mechanical torque that is transmitted to the vehicle wheels. In many modern electric vehicles, brushless DC motors are preferred because they provide higher efficiency, low noise, and minimal maintenance.

Vehicle Wheels



Fig 7: Vehicle Wheels

The vehicle wheels receive rotational motion from the motor. As the motor shaft rotates, mechanical power is transferred through the drivetrain to the wheels. This rotational movement enables the vehicle to move forward or backward depending on the motor direction. The wheels ultimately convert the motor's rotational energy into vehicle motion.

Regenerative Braking (Optional)

The regenerative braking system is an optional energy recovery feature. During braking or when the vehicle slows down, the DC motor temporarily works as a generator instead of consuming electrical energy. The kinetic energy of the moving vehicle is converted back into electrical energy. This recovered energy is then sent through the controller and stored in the battery pack. Regenerative braking improves overall energy efficiency and helps increase the driving range of the electric vehicle.



Overall Working of the System

In this system, sunlight is converted into electrical energy by the solar panel. The charge controller regulates this energy and safely stores it in the battery pack. The stored energy is then supplied to the motor controller, which manages the power delivered to the DC motor based on driver input. The motor converts electrical energy into mechanical motion that drives the vehicle wheels. During braking, regenerative braking may recover part of the energy and return it to the battery, improving system efficiency and sustainability.

VII. MATHEMATICLE EQUENTION

1. Total Load Calculation

Total load on the vehicle is the sum of the vehicle weight and passenger weight.

Using the relation:

$$\text{Total Load} = \text{Vehicle Weight} + \text{Passenger Weight}$$

Passenger load:

$$5 \times 70 = 350kg$$

Therefore,

$$\text{Total Load} = 320 + 350 = 670kg$$

2. Wheel Diameter Conversion

Wheel diameter is given in feet and converted into meters.

$$1.3ft = 0.3962m$$

So,

$$D = 0.3962m$$

3. Wheel Circumference

$$C = \pi \times D$$

$$C = 3.14 \times 0.3962$$

$$C = 1.244m$$

4. Wheel RPM

$$\text{Wheel RPM} = \frac{500}{3}$$

$$\text{Wheel RPM} = 166.66 \text{ RPM}$$

5. Vehicle Speed

$$\text{Speed} = \frac{\text{Wheel RPM} \times \text{Circumference} \times 60}{1000}$$

$$\text{Speed} = \frac{166.66 \times 1.244 \times 60}{1000}$$

$$\text{Speed} = 12.43 \text{ km/h}$$



6. Battery Energy

Battery specifications:

Voltage per battery = 12 V

Number of batteries = 4

Capacity = 240 Ah

Total battery voltage:

$$V_{total} = 4 \times 12 = 48 V$$

Total battery energy:

$$E = V \times Ah$$

$$E = 48 \times 240$$

$$E = 11520 Wh$$

8. Vehicle Range

$$\text{Range} = \frac{\text{Total Battery Energy}}{\text{Energy Per Km}}$$

$$\text{Range} = \frac{11520}{211.604}$$

$$\text{Range} = 54.44 \text{ km}$$

Final Results

Total Load = 670 kg

Vehicle Speed = 12.43 km/h

Energy Consumption = 211.604 Wh/km

Estimated Range = 54.44 km

VIII. RESULT AND DISCUSSION

The developed electric vehicle prototype was successfully fabricated and assembled using a lightweight metal frame, protective body panels, and a covered passenger cabin.

The fabricated prototype demonstrates the practical implementation of an electric vehicle designed for short-distance transportation. The integration of electric drive components such as the motor, battery pack, and controller allows the vehicle to operate efficiently with minimal noise and zero direct emissions. The lightweight construction and compact design improve vehicle maneuverability and reduce power consumption during operation. Based on the design calculations and system configuration, the vehicle can achieve a moderate operational speed and an estimated driving range suitable for campus mobility, industrial areas, and short urban transportation. Overall, the prototype successfully validates the feasibility of developing a low-cost and environmentally friendly electric vehicle system for sustainable transportation applications.





Fig 8: Side view of model



Fig 9: Front view of model



IX. CONCLUSION

The development of the electric vehicle prototype demonstrates an effective and environmentally friendly transportation solution that utilizes electrical energy instead of conventional fossil fuels. The system integrates essential components such as the battery pack, motor controller, electric motor, and supporting structural framework to achieve efficient vehicle operation. The designed vehicle structure provides sufficient strength while maintaining a lightweight configuration, which improves energy efficiency and vehicle performance. The implemented system successfully converts stored electrical energy into mechanical motion to drive the vehicle, proving the feasibility of using electric propulsion for short-distance transportation. The prototype also highlights the advantages of electric vehicles, including reduced air pollution, lower operational costs, minimal noise generation, and improved energy utilization compared to traditional internal combustion engine vehicles.

FUTURE SCOPE

In the future, the electric vehicle system can be further enhanced by integrating solar panels on the vehicle roof to enable renewable energy-based charging, which would improve energy sustainability and reduce dependency on external power sources. Advanced battery technologies with higher energy density can also be implemented to increase the driving range and reduce charging time. Additionally, implementing smart battery management systems and IoT-based monitoring can help track battery performance, energy consumption, and system health in real time.

REFERENCES

- [1]. Y. Xing, E. W. M. Ma, K. L. Tsui, and M. Pecht, "Battery management systems in electric and hybrid vehicles," *Energies*, vol. 14, no. 5, pp. 1–18, 2022.
- A. Emadi, L. Young-Joo, and K. Rajashekara, "Power electronics and motor drives in electric, hybrid electric, and plug-in hybrid electric vehicles," *IEEE Transactions on Industrial Electronics*, vol. 69, no. 4, pp. 3354–3363, 2022.
- [2]. J. Cao and A. Emadi, "A new battery/ultra-capacitor hybrid energy storage system for electric vehicles," *IEEE Transactions on Power Electronics*, vol. 38, no. 2, pp. 1845–1856, 2023.
- [3]. H. Zhang, J. Li, and L. Wang, "Recent advances in battery management systems for electric vehicles," *Renewable and Sustainable Energy Reviews*, vol. 168, pp. 112–125, 2023.
- [4]. S. Kumar, P. Sharma, and R. Gupta, "Design and performance analysis of solar powered electric vehicles," *Energy Reports*, vol. 9, pp. 220–231, 2023.
- [5]. M. Ehsani, Y. Gao, and A. Emadi, *Modern Electric, Hybrid Electric, and Fuel Cell Vehicles: Fundamentals, Theory and Design*, CRC Press, 2022.
- A. Khaligh and Z. Li, "Battery, ultracapacitor, fuel cell, and hybrid energy storage systems for electric vehicles," *IEEE Transactions on Vehicular Technology*, vol. 72, no. 1, pp. 23–37, 2023.
- [6]. P. Pillay and R. Krishnan, "Modeling and performance analysis of brushless DC motor drives for electric vehicle applications," *IEEE Transactions on Industry Applications*, vol. 59, no. 3, pp. 3158–3166, 2023.
- [7]. T. B. Reddy, *Lithium-Ion Batteries for Electric Vehicles: Fundamentals and Applications*, McGraw-Hill, 2022.
- A. Singh, V. Kumar, and R. Mishra, "Design and development of a low-cost electric vehicle prototype," *International Journal of Automotive Technology*, vol. 25, no. 2, pp. 145–156, 2024.
- [8]. M. Rahman, T. Islam, and S. Hossain, "Solar integrated electric vehicle charging system for sustainable transportation," *Energy Reports*, vol. 10, pp. 1250–1262, 2024.
- [9]. K. Gupta and A. Verma, "Energy recovery analysis of regenerative braking systems in electric vehicles," *Journal of Energy Storage*, vol. 70, pp. 107–115, 2023.
- [10]. J. Larminie and J. Lowry, *Electric Vehicle Technology Explained*, 2nd ed., Wiley, 2022.



- [11]. N. K. Sharma and P. Bansal, "Design considerations of electric vehicle propulsion systems," *International Journal of Power Electronics and Drive Systems*, vol. 14, no. 1, pp. 205–213, 2023.
- [12]. B. K. Bose, *Power Electronics and Motor Drives: Advances and Trends*, Academic Press, 2022

