

IoT-Based Smart Home Power Monitoring System

Miss. Rasika A. Barde¹, Mr. Nitin S. Panode², Mr. Sarthak J. Kurhade³, Miss. Janhavi P. Rathod⁴,
Miss. Radhika M. Tupe⁵, Miss. Durga G. Mali⁶, Miss. Janhavi A. Kudmethe⁷, Prof. A. S. Alone⁸

¹²³⁴⁵⁶⁷Students, Department of Electrical Engineering

⁸Assistant Professor, Department of Electrical Engineering,

Jawaharlal Darda Institute of Engineering and Technology Yavatmal, Maharashtra, India

Abstract: *This paper presents an IoT-based smart home power monitoring system aimed at improving energy efficiency and ensuring reliable power management. The system monitors voltage levels of multiple power sources using sensors connected to a microcontroller and automatically switches between them based on predefined thresholds and priority logic. This approach minimizes energy loss and protects batteries from deep discharge. An IoT interface enables real-time remote monitoring and control via a mobile application, while a local display provides system status. The design supports both automatic and manual modes, offering flexibility to users. The proposed system is cost-effective, scalable, and well-suited for modern residential energy management.*

Keywords: *IoT, Smart Home, Power Monitoring, Energy Management, Voltage Monitoring, Grid Switching, ESP32, Automation*

I. INTRODUCTION

In today's technological era, the demand for efficient, reliable, and intelligent energy management in residential environments is rapidly increasing. Modern smart homes integrate multiple power sources such as batteries, inverters, and renewable energy systems, which require continuous and optimized power management. However, conventional systems still rely on manual control and lack real-time monitoring, leading to inefficient energy utilization and reduced overall system performance [1].

This issue is more prominent in traditional home power systems, where users must manually monitor battery status and switch between power sources with limited information. Such methods are time-consuming and prone to errors, resulting in energy wastage, unexpected power failures, and decreased battery life [2]. Moreover, the lack of intelligent automation and remote access limits users' ability to manage energy efficiently in real-time and changing conditions [3].

To address these challenges, this research proposes an IoT-based Smart Home Power Monitoring and Intelligent Energy Management System that introduces a centralized and automated approach to residential power management. Unlike conventional systems that operate in isolation with limited functionality, the proposed system integrates real-time voltage monitoring, priority-based decision-making, and automated power source switching within a unified framework [4]. By continuously monitoring battery conditions and system parameters, the system optimizes energy usage and ensures a reliable power supply. The proposed design is based on a multi-source energy management architecture that integrates voltage sensing, microcontroller-based control, relay switching, and IoT communication [5]. This integration enables users to remotely monitor and control the system through a mobile interface, improving flexibility and convenience. Unlike traditional systems with limited monitoring and manual control, the proposed system incorporates automation, real-time decision-making, and intelligent energy management [6]. By combining hardware-based monitoring with IoT-based remote interaction, the system creates a comprehensive and efficient energy management solution suitable for modern smart homes.



II. LITERATURE REVIEW

Ref.	Author	Focus Area	Key Contribution	Limitation
[1]	1] Pavithra D., Ranjith Balakrishnan 2015	IoT based Monitoring and Control System for Home Automation	Limited focus on data security and privacy; no performance evaluation under heavy network load	Low-cost implementation using Raspberry Pi; remote control via smartphone;
[2]	2] P. S. N. Reddy 2015	IoT-based Home Automation System	No comparison with other protocols like MQTT/CoAP	Low-cost; easy web-based interface
[3]	3] T. S. Gunawan 2016	Prototype Design of Smart Home System	Limited integration with cloud and AI-based decision making	Simple architecture; easy implementation for beginners
[4]	4] Jetendra Joshi et al. 2017	Performance Enhancement and IoT Based Monitoring for Smart Home	Lacks real-world large-scale deployment results; limited long-term reliability testing	Supports multiple protocols, low-cost; scalable architecture
[5]	5] Waheb A. Jabbar et al. 2018	Design and Implementation of IoT-Based Automation System for Smart Home	Does not address cloud security and data privacy; limited user behavior analysis	Simple Wi-Fi based control; user-friendly Android app; cost-effective Arduino platform

III. PROBLRM STATEMENT

Electrical cables used in residential, commercial, and industrial systems often develop hidden faults such as insulation degradation, leakage current paths, moisture intrusion, and conductor displacement. These issues disturb the electric field around the cable and can lead to shocks, short circuits, equipment failure, or fire hazards if not detected early. Traditional tools require direct contact, insulation penetration, or skilled handling, making them unsafe and unsuitable for quick inspections. Non-contact testers only show voltage presence and cannot identify insulation weakness or fault direction. Therefore, a compact, safe, and intelligent non-contact device is needed to detect electric-field distortion and accurately locate cable faults.

IV. METHODOLOGY / WORKING

The proposed IoT-based smart home power monitoring system operates using real-time voltage sensing, intelligent control, and automatic source switching. It continuously monitors available power sources and maintains an uninterrupted supply through a priority-based mechanism. Voltage sensors measure the levels of multiple batteries, and the analog signals are processed by a microcontroller. These values are compared with predefined thresholds to determine the condition and availability of each battery [1]. Real-time monitoring allows the system to detect low-voltage conditions and prevent battery over-discharge. Based on this data, the microcontroller selects the most appropriate power source using a decision-making algorithm. Under normal conditions, the primary battery is used. If



its voltage falls below a set limit, the system switches to a secondary battery. When both batteries are insufficient, the system automatically shifts to the main grid to ensure continuous power supply [2].

The switching operation is performed using relay modules that connect the load to the selected power source. This automatic mechanism enables smooth transitions between sources without interrupting the power supply [3]. In addition to automatic operation, the system supports manual control through an IoT interface. A Wi-Fi module enables users to remotely monitor parameters such as battery voltage, active source, and grid status via a mobile application. It also allows manual switching, providing greater flexibility in system control [4]. For local monitoring, an LCD display provides real-time information on system status, including battery levels and the active power source. This improves user awareness and allows easy interaction without relying on external devices [5].

Overall, the system integrates sensing, control, decision-making, and communication into a unified framework, ensuring efficient energy management, higher reliability, and minimal manual intervention in smart homes [6].

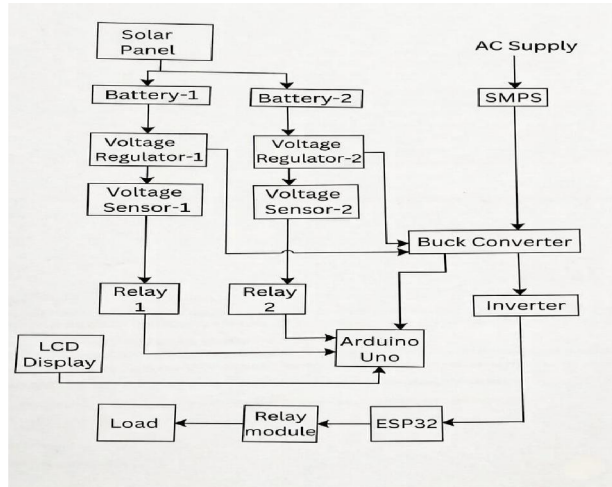

Figure 1 : Block Diagram of IOT-Based Smart Home Power Monitoring

V. CIRCUIT DIAGRAM

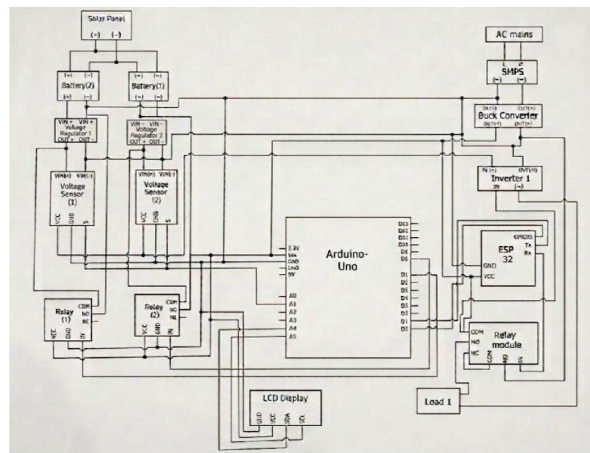

Figure 2 : Circuit Diagram of IOT-Based Smart Home Power Monitoring

The circuit diagram represents an IoT-based smart home power monitoring system integrating multiple energy sources, including batteries, a solar panel, and the main grid. Voltage sensors continuously measure battery levels



and send signals to the Arduino Uno, which acts as the central controller. Based on predefined conditions, the Arduino controls relay modules to automatically switch between power sources, ensuring uninterrupted supply to the load. An ESP32 module enables wireless communication for remote monitoring and control, while an LCD displays real-time system status. Additional components such as a buck converter, SMPS, and inverter provide regulated power and support efficient system operation.

VI. EXPERIMENTAL SETUP



Figure 3 : Experimental Setup Diagram of IOT-Based Smart Home Power Monitoring

VII. HARDWARE TOOLS

1. SOLAR PANEL



Fig. 4 : Solar Panel

A solar panel generates DC power from sunlight using the photovoltaic effect. In this system, it acts as an additional energy source, charging the battery through a charge controller for safe storage. This helps ensure continuous power supply, reduces grid dependence, and enhances overall efficiency and reliability.

2. ARDUINO UNO



Fig. 5 : Arduino Uno

The Arduino Uno serves as the main controller of the system, monitoring battery voltage and making decisions based on preset thresholds. It controls the relay for automatic switching, displays system status on the LCD, and communicates with the ESP32 for remote monitoring.

3. 18650 BATTERY



Fig. 6 : 18650 Battery



The 18650 lithium-ion battery is used for energy storage due to its high energy density and long lifespan. In this system, it supplies power when the grid is unavailable. Continuous monitoring ensures safe operation by preventing overcharging and deep discharge, thereby improving reliability and battery life.

4. BUCK CONVERTER



Fig. 7 : Buck Converter

The buck converter is a DC-DC device that steps down voltage efficiently to the required level. In this system, it supplies a stable and regulated voltage to components such as the Arduino, ESP32, and sensors, improving efficiency and protecting them from overvoltage.

5. VOLTAGE REGULATOR

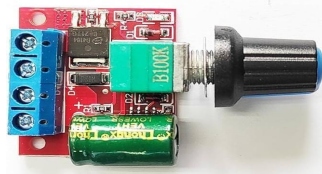

Fig. 8 : Voltage Regulator

The voltage regulator ensures a constant output voltage for proper system operation. It provides stable power to components such as the Arduino, ESP32, and sensors, protecting them from voltage fluctuations and improving overall reliability and performance.

6. ESP32



Fig. 10 : ESP32

The ESP32 is a microcontroller with built-in Wi-Fi and Bluetooth for IoT applications. In this system, it enables remote monitoring and control by sending data to a mobile application, allowing users to track system status and manage power sources in real time.

7. VOLTAGE SENSOR

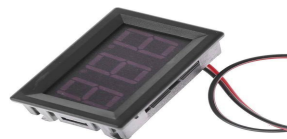

Fig. 11 : Voltage Sensor

The voltage sensor measures the voltage level of batteries and converts it into a signal readable by the microcontroller. In this system, it provides real-time voltage data for decision-making and helps in detecting low or abnormal conditions, ensuring safe and efficient operation.



8. RELAY MODULE

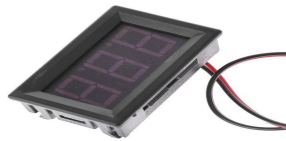

Fig. 12 : Relay Module

The relay module acts as a switching device controlled by the microcontroller to select between different power sources. It enables automatic switching between batteries and the grid, while providing electrical isolation for safe and reliable operation.

9. SPST SWITCH



Fig. 13 : SPST Switch

The SPST (Single Pole Single Throw) switch is a simple on/off switch used to control the flow of current. In this system, it provides manual control of the power supply or grid connection. It ensures safe operation and allows easy switching during maintenance or emergencies.

10. 200W INVERTER KIT

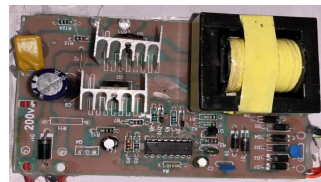

Fig. 14 : . 200w Inverter Kit

The 200W inverter kit converts DC power from batteries into AC power for household appliances. In this system, it supplies AC power during grid failure and supports uninterrupted operation. It works with the switching mechanism to provide reliable backup power.

11. 16x12 LCD



Fig. 15 : 16x12 LCD

The 16x2 LCD display is used to show real-time system information. In this system, it displays battery voltage, power source, and system status. It provides a simple user interface for easy monitoring and improves system usability.



12. I2C MODULE



Fig. 16 : I2C Module

The I2C module is used for communication between the microcontroller and display using two wires (SDA and SCL). In this system, it connects the LCD with the Arduino and reduces wiring complexity. It ensures efficient communication and saves microcontroller pins.

13. BULB



Fig. 17 : Bulb

The bulb is used as a load to represent electrical appliances in the system. It indicates power supply by glowing when a source is active. It helps in testing power switching and verifying system performance and reliability.

14. LEDs



Fig. 18 : LEDs

LEDs are semiconductor devices that emit light when current flows through them. In this system, they are used as indicators to show power source status and system conditions. They provide quick visual feedback and help in monitoring and debugging.

15. CONNECTING WIRES



Fig. 19 : Connecting Wires

Connecting wires are used to establish electrical connections between system components. In this system, they ensure proper transmission of power and signals between devices. They support reliable operation and help in easy assembly and maintenance of the circuit.

VIII. ADVANTAGES

- Enables real-time monitoring of battery voltage and system status
- Ensures uninterrupted power supply through automatic switching
- Minimizes energy loss and improves overall efficiency
- Prevents battery over-discharge and enhances battery life
- Supports remote monitoring and control via IoT
- Reduces manual effort and human errors



- Cost-effective and suitable for smart home applications
- Enhances system reliability and performance

IX. DISADVANTAGES

- Higher initial setup cost compared to conventional systems
- Requires internet connectivity for IoT-based monitoring and control
- Increased system complexity due to multiple components
- Depends on accurate sensor readings for proper operation
- Requires periodic maintenance of electronic components
- Limited scalability without modifications for large-scale use
- Possible delays in remote communication and monitoring

X. FUTURE SCOPE

- Integration with renewable sources such as solar and wind energy
- Implementation of AI-based energy prediction and optimization
- Development of advanced mobile applications with analytics features
- Integration with smart grid and smart meter systems
- Inclusion of fault detection and alert notification mechanisms
- Scalability for large-scale residential and industrial applications
- Cloud-based data storage for long-term analysis
- Improved security for IoT communication

XI. RESULT

The proposed IoT-based smart home power monitoring system was successfully implemented and evaluated. It monitored battery voltages in real time and enabled automatic switching between multiple power sources based on priority. The system ensured fast switching and uninterrupted power supply. Remote monitoring and control were achieved through ESP32-based connectivity, while manual control supported offline operation. Overall, the system demonstrated reliable performance and effective energy management.



Fig. 19



Fig. 20



Fig. 21



Fig. 22



Fig. 23



XII. CONCLUSION

The IoT-based smart home power monitoring system ensures efficient energy use and continuous power supply. It monitors battery voltage and automatically switches between batteries and the grid. With Arduino Uno and ESP32, it enables real-time monitoring, remote control, and battery protection, making it a reliable and cost-effective solution for smart homes.

REFERENCES

- 1] P. D. Pavithra and R. Balakrishnan, "IoT based monitoring and control system for home automation," in Proceedings of the 2015 Global Conference on Communication Technologies (GCCT), Chennai, India, Apr. 2015, pp. 169-173, doi: 10.1109/GCCT.2015.7342646.
- 2] J. Joshi, V. Rajapriya, S. R. Rahul, P. Kumar, S. Polepally, R. Samineni, and D. G. Kamal Tej, "Performance enhancement and IoT based monitoring for smart home," in Proceedings of the IEEE International Conference on Information and Communication Technology Convergence (ICOIN), Rajasthan, India, Jan. 2017, pp. 468-473, doi: 10.1109/ICOIN.2017.7899537.
- 3] W. A. Jabbar, M. H. Alsibai, N. S. S. Amran, and S. K. Mahayadin, "Design and implementation of IoT based automation system for smart home," in Proc. IEEE Int. Symp. Networks, Computers and Communications (ISNCC), Rome, Italy, 2018, pp. 1-6, doi: 10.1109/ISNCC.2018.8531006.
- 4] G.-L. Huang, A. Anwar, S. W. Loke, A. Zaslavsky, and J. Choi, "IoT-based analysis for smart energy management," arXiv preprint arXiv:2311.18643, Aug. 2023.
- 5] P. S. N. Reddy, K. T. K. Reddy, P. A. K. Reddy, G. N. K. Ramaiah, and S. N. Kishor, "An IoT based home automation using Android application," in Proc. Int. Conf. on Signal Processing, Communication, Power and Embedded System (SCOPEs), 2016, pp. 285-290, doi: 10.1109/SCOPEs.2016.7955836.
- 6] C. K. Rao, S. K. Sahoo, and F. F. Yanine, "A literature review on an IoT-based intelligent smart energy management systems for PV power generation," "Hybrid Advances, vol. 5, Art. no. 100136, 2024, doi: 10.1016/j.hybadv.2023.100136.
- 7] P. Siva Nagendra Reddy, K. Tharun Kumar Reddy, P. Ajay Kumar Reddy, G. N. K. Ramaiah, and S. Nanda Kishor, "An IoT based home automation using Android application," in Proc. Int. Conf. Signal Processing, Communication, Power and Embedded System (SCOPEs), Chennai, India, 2016, pp. 285-290, doi: 10.1109/SCOPEs.2016.7955836.
- 8] Bagdadee, A. H., Rahman, M. S., Mamoon, I. A., Dewi, D. A., Islam, A. K. M. M., and Zhang, L., "Empowering smart homes by IoT-driven hybrid renewable energy integration for enhanced efficiency," Scientific Reports, vol. 15, Art. no. 41491, 2025, doi: 10.1038/s41598-025-25328.
- 9] S. Umer, Y. Tan, and A. O. Lim, "Priority based power sharing scheme for power consumption control in smart homes," International Journal of Smart Grid and Clean Energy, vol. 3, no. 3, pp. 341-346, July 2014.

