

# Development of Multipurpose Hydraulic Wheel Dolly

Amit J. Patil<sup>1</sup>, Raj Shinde<sup>2</sup>, Siddhesh Kamble<sup>3</sup>, Vighnesh Raut<sup>4</sup>, Mrigaj Mhatre<sup>5</sup>,  
Lecturer, Department of Mechanical Engineering<sup>1</sup>  
Students, Department of Mechanical Engineering<sup>2,3,4,5</sup>  
Bharati Vidyapeeth Institute of Technology, Navi Mumbai, India

**Abstract:** *In modern automotive workshops and industries, efficient handling and movement of heavy vehicles is a major challenge. The hydraulic wheel dolly is a mechanical device designed to lift and move vehicles with minimal effort using hydraulic principles. It allows a single operator to easily reposition vehicles without starting the engine. This paper presents an overview of the hydraulic wheel dolly, including its working principle, components, applications, advantages, limitations, and future scope. The study highlights how hydraulic wheel dollies improve safety, reduce manual labour, and increase operational efficiency in garages and industrial environments.*

**Keywords:** *Hydraulic Wheel Dolly, Hydraulics, Vehicle Handling, Workshop Equipment, Lifting Mechanism*

## I. INTRODUCTION

The automotive and industrial sectors require efficient methods for handling heavy loads such as vehicles and machinery. Traditional methods of moving vehicles manually are time-consuming and require significant effort. With advancements in hydraulic systems, devices like the hydraulic wheel dolly have been developed to simplify this process. A hydraulic wheel dolly enables easy lifting and movement of vehicles by applying hydraulic pressure. It is widely used in garages, workshops, and parking management systems.

This project focuses on understanding the design, working, and applications of a hydraulic wheel dolly and its importance in improving efficiency and safety.

## II. HYDRAULIC WHEEL DOLLY

A hydraulic wheel dolly is a portable lifting device used to lift vehicle wheels slightly off the ground and allow movement in any direction. It works on the principle of hydraulic pressure, where force is multiplied using fluid pressure.

The dolly consists of wheels, a hydraulic pump, lifting arms, and a frame. When the hydraulic system is activated, the lifting arms raise the vehicle tire, allowing smooth movement.

## III. PRINCIPLE OF OPERATION

The hydraulic wheel dolly operates based on the principle of Pascal's Law, which states that when pressure is applied to a confined fluid, it is transmitted equally and undiminished in all directions. This fundamental principle enables the system to multiply force and perform heavy lifting tasks efficiently. In a hydraulic wheel dolly, a closed system filled with fluid is used to transfer force from one point to another, allowing a small input force to generate a much larger output force.

When an external force is applied to the hydraulic pump, it creates pressure within the hydraulic fluid contained in the system. Since the fluid is incompressible, the applied pressure is distributed uniformly throughout the fluid. This pressure acts on the surfaces of the piston inside the hydraulic cylinder. As a result, the piston experiences a force that causes it to move upward or forward, depending on the design of the system.



#### **IV. NEED FOR HYDRAULIC WHEEL DOLLY**

The need for hydraulic wheel dollies arises primarily due to the challenges associated with moving non-operational or immobilized vehicles. In situations where a vehicle cannot be driven due to mechanical failure, lack of fuel, or damage, manually pushing or dragging it becomes extremely difficult and inefficient. Hydraulic wheel dollies provide a practical solution by allowing the wheels of the vehicle to be lifted and supported, enabling smooth movement without requiring the vehicle's engine to function.

Another important requirement for hydraulic wheel dollies is the need for precise vehicle positioning. In workshops, service stations, and parking areas, vehicles often need to be aligned accurately for repair work or efficient space utilization. Manual methods may lack precision and can be time-consuming. By using hydraulic dollies, operators can easily manoeuvre vehicles in any direction, ensuring accurate placement while significantly reducing manual labour and physical effort. This not only improves productivity but also minimizes the risk of strain or injury to workers.

#### **V. RESEARCH OBJECTIVES OF THE PROJECT**

The main objective of studying a hydraulic wheel dolly is to understand its fundamental working principle, which is based on hydraulic systems and fluid mechanics. This involves analysing how force is transmitted through a confined fluid and how it results in the lifting and movement of heavy loads. By gaining knowledge of this principle, one can better appreciate the efficiency and effectiveness of hydraulic devices in practical applications.

Another important objective is to understand the design and components of the hydraulic wheel dolly. This includes studying various parts such as the hydraulic pump, cylinder, piston, valves, and the structural frame of the dolly. A clear understanding of these components and their functions helps in analysing how the system operates. Additionally, examining its applications in different industries, such as automobile workshops, garages, and parking facilities, provides insight into its practical usefulness and versatility.

#### **VI. CONSTRUCTION AND COMPONENTS**

The hydraulic wheel dolly is composed of several essential components that work together to ensure efficient lifting and movement of heavy vehicles. The primary structure of the dolly is the frame, which serves as a strong and stable base supporting the entire system. It is designed to withstand heavy loads and provide durability during operation. Mounted on this frame is the hydraulic pump, which plays a crucial role in generating the pressure required to lift the load. When force is applied to the pump, it pressurizes the hydraulic fluid within the system.

The pressurized fluid is then directed into the hydraulic cylinder, which converts the hydraulic energy into mechanical motion. Inside the cylinder, a piston moves in response to the fluid pressure, producing the lifting action. This motion is transferred to the lifting arms, which are specifically designed to securely hold and lift the vehicle tire. The lifting arms ensure proper grip and stability, preventing the wheel from slipping during operation. Together, these components enable the dolly to lift heavy.

#### **VII. WORKING PROCESS**

The working of a hydraulic wheel dolly begins by carefully positioning the dolly under the vehicle wheel that needs to be lifted. Proper placement is important to ensure stability and effective operation. Once the dolly is correctly aligned, the operator starts pumping the hydraulic pedal or handle. This manual action activates the hydraulic pump, initiating the process of pressure generation within the system.

As the pedal or handle is pumped, hydraulic fluid inside the system is pressurized and directed into the hydraulic cylinder. Due to this pressure, the piston inside the cylinder begins to move. The movement of the piston is then transferred to the lifting mechanism of the dolly, causing the wheel to rise. Gradually, the vehicle wheel is lifted slightly above the ground, ensuring that it is free from surface contact and can move without resistance. Once the wheel is elevated, the vehicle can be easily moved in any direction using the caster wheels provided on the dolly. This allows for smooth and precise repositioning of the vehicle, even in tight spaces. After the required movement is completed, the operator uses the release valve to lower the wheel safely. By controlling the release of



hydraulic pressure, the wheel is gently brought back to the ground, ensuring a smooth and controlled operation without sudden drops.

### **VIII. FEATURES OF HYDRAULIC WHEEL DOLLY**

The hydraulic wheel dolly offers ease of operation, making it highly convenient for users in workshops and garages. Its simple working mechanism allows even a single operator to use it efficiently without requiring specialized skills or extensive training. Unlike traditional methods of moving vehicles, which demand significant physical effort, the hydraulic system reduces the need for manual force. As a result, it requires less manpower, making it a cost-effective and time-saving solution for handling vehicles.

Another significant advantage of the hydraulic wheel dolly is its high load carrying capacity combined with smooth and flexible movement. The hydraulic mechanism enables the dolly to lift heavy vehicle wheels with minimal effort, while the sturdy construction ensures it can handle substantial loads safely. Additionally, the presence of caster wheels allows for easy and flexible movement in all directions, making it possible to manoeuvre vehicles even in confined or crowded spaces. This smooth mobility enhances efficiency and precision during vehicle positioning.

Furthermore, the hydraulic wheel dolly is designed to be compact, portable, and highly durable. Its compact size allows for easy storage and transportation, while its robust construction ensures long-term reliability even under frequent use. The materials used in its design provide strength and resistance to wear and tear. Most importantly, it ensures safe handling of vehicles by offering controlled lifting and lowering mechanisms, reducing the risk of accidents or damage. Overall, these features make the hydraulic wheel dolly a dependable and practical tool in automotive applications.

### **IX. APPLICATIONS**

Hydraulic wheel dollies are widely used in automotive workshops where efficient handling of vehicles is essential for repair and maintenance activities. In such environments, vehicles often need to be moved frequently for inspection, servicing, or part replacement. The use of hydraulic dollies allows mechanics to lift and relocate vehicles with ease, even if they are not operational. Additionally, these dollies are highly useful for positioning vehicles in tight or confined spaces within the workshop, ensuring better utilization of available space and smoother workflow. In parking management systems, hydraulic wheel dollies play an important role in organizing and rearranging vehicles efficiently. They help in adjusting vehicle positions to maximize parking capacity, especially in crowded areas. Moreover, they are particularly useful for handling blocked or non-starting cars that cannot be moved using conventional methods. By lifting the wheels and enabling smooth movement, these dollies simplify the task of relocating such vehicles without causing inconvenience or damage.

Apart from automotive applications, hydraulic wheel dollies are also used in industrial settings, garages, and service centres. In industries, they assist in the movement of heavy machinery and equipment within factory premises, reducing manual effort and increasing safety. In garages and service centres, they provide an easy and quick method for shifting vehicles from one place to another, saving time and improving operational efficiency. Overall, their versatility and effectiveness make them a valuable tool across multiple sectors.



### X. CAD DRAWINGS

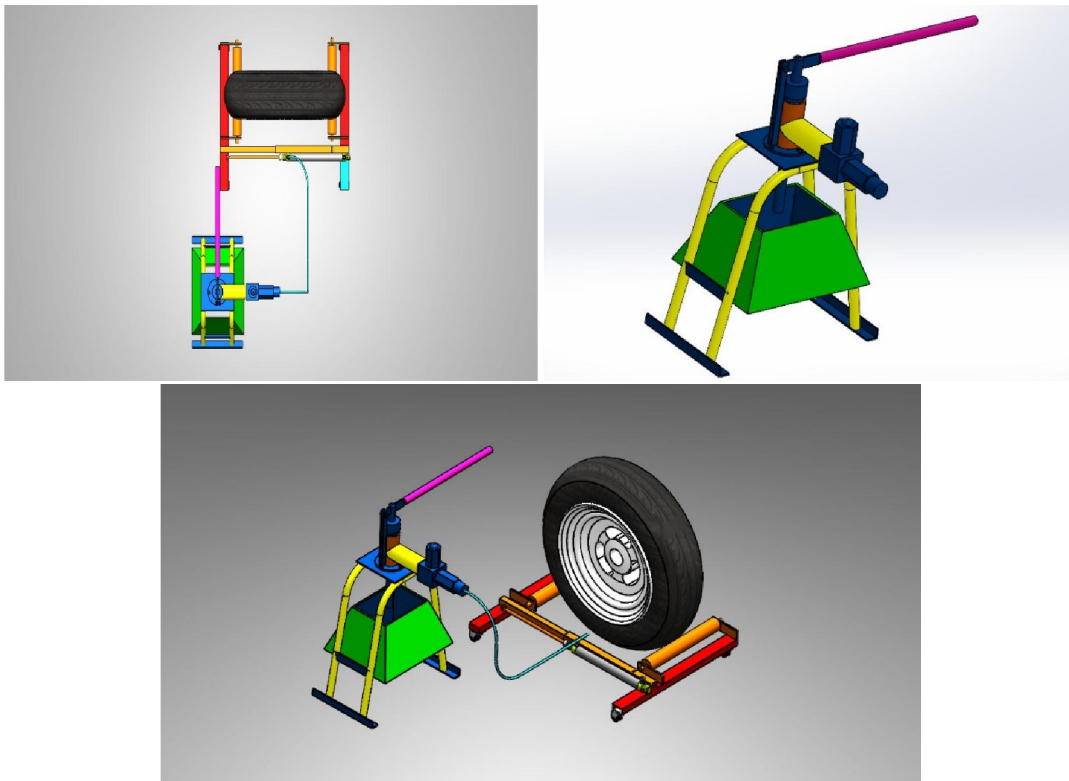

### XI. ADVANTAGES

The hydraulic wheel dolly provides significant benefits by greatly reducing manual effort required in handling heavy vehicles. Traditional methods of moving vehicles often involve pushing or lifting, which can be physically exhausting and inefficient. With the help of a hydraulic mechanism, the dolly allows operators to lift heavy loads with minimal force. This not only makes the task easier but also saves a considerable amount of time, enabling faster completion of work in workshops and garages.

Another important advantage of the hydraulic wheel dolly is the improvement in safety and ease of operation. Since the system uses controlled hydraulic pressure for lifting and lowering, it minimizes the risk of sudden movements or accidents. The simple design and user-friendly operation allow even a single person to handle the equipment efficiently without requiring special training. This ensures a safer working environment and reduces the chances of injury or damage to vehicles.

### XII. LIMITATIONS

Despite its many advantages, the hydraulic wheel dolly has certain limitations that must be considered before its use. One of the primary drawbacks is its high initial cost compared to conventional manual equipment. The use of hydraulic components and durable materials increases the overall manufacturing cost, making it a relatively expensive investment for small workshops or individual users. However, this cost is often justified by its efficiency and long-term benefits. Another important limitation is the requirement for regular maintenance. Hydraulic systems depend on proper functioning of components such as pumps, cylinders, and valves, which need periodic inspection and servicing. Issues such as hydraulic fluid leakage can occur due to wear and tear of seals or improper handling, which can affect the



performance of the dolly and lead to safety concerns. Therefore, proper maintenance practices are essential to ensure reliable and safe operation.

### **XIII. FUTURE SCOPE**

Future improvements in hydraulic wheel dollies may focus on the integration of electric and automated systems to enhance ease of operation and efficiency. By incorporating electric actuators or motorized hydraulic pumps, the need for manual effort can be further reduced or completely eliminated. Automation can also allow for more precise control of lifting and movement, making the system more user-friendly and suitable for modern workshops and industrial environments where efficiency and speed are critical.

Another important area of development is the use of smart hydraulic control systems with advanced sensors. These sensors can monitor parameters such as load weight, pressure levels, and stability in real time, ensuring safer and more accurate operation. Smart systems can also include features like automatic pressure adjustment and overload protection, reducing the chances of equipment failure or accidents. This integration of technology can significantly improve reliability, safety, and overall performance of the hydraulic wheel dolly.

### **XIV. CONCLUSION**

The hydraulic wheel dolly is an essential tool in modern automotive and industrial applications. It provides an efficient and safe method for lifting and moving vehicles with minimal effort.

### **XV. ACKNOWLEDGEMENT**

We would like to thank all the authors of different research papers referred to while writing this paper. It was very knowledgeable and helpful for the further research to be done in future.

### **REFERENCES**

- [1] R.S. Khurmi and J.K. Gupta, *A Textbook of Hydraulic Machines*, S. Chand Publications, New Delhi.
- [2] R.K. Bansal, *Fluid Mechanics and Hydraulic Machines*, Laxmi Publications, India.
- [3] P.N. Modi and S.M. Seth, *Hydraulics and Fluid Mechanics*, Standard Book House.
- [4] V. B. Bhandari, *Design of Machine Elements*, McGraw Hill Education.
- [5] Hibbeler, R.C., *Engineering Mechanics: Statics and Dynamics*, Pearson Education.
- [6] Mott, R.L., *Applied Fluid Mechanics*, Pearson.
- [7] Esposito, A., *Fluid Power with Applications*, Pearson Education.
- [8] Bosch Rexroth, *Hydraulic Systems and Components Manual*, Industrial Training Manual.
- [9] Parker Hannifin Corporation, *Introduction to Hydraulics*, Technical Handbook.
- [10] ISO 4413:2010, *Hydraulic Fluid Power – General Rules and Safety Requirements for Systems and Their Components*.
- [11] Research Articles on Hydraulic Lifting Devices, *International Journal of Mechanical Engineering (IJME)*.
- [12] Study on Vehicle Handling Equipment, *IEEE Xplore Digital Library*

