

Wifi Enabled Monitoring, Control and Protection of Solar Fed Induction Motor

S. Ramu¹, J. Prashanth², N. Sanjay Reddy³

Department of Electrical and Electronics Engineering¹⁻³

ACE Engineering College, Hyderabad, India

Abstract: This paper presents the design and implementation of a solar-powered, digitally protected single-phase induction motor control system using Pulse Width Modulation (PWM) technology. The proposed system integrates renewable energy with intelligent monitoring and protection mechanisms to enhance operational efficiency, safety, and reliability. A 12V, 10W solar panel is employed to charge a 12V, 5Ah rechargeable battery, providing a sustainable power source for motor operation. An Arduino Nano-based microcontroller unit forms the core of the control architecture. Linear speed control of the single-phase induction motor is achieved through PWM techniques, enabling efficient and precise regulation of motor performance. The system incorporates real-time monitoring of critical parameters, including motor body temperature and battery voltage. An LM35 temperature sensor continuously measures the motor temperature, which is displayed on an LCD interface. Automatic shutdown is triggered when the temperature exceeds 50°C to prevent thermal damage. Similarly, the battery voltage is monitored, and the motor supply is disconnected if the voltage falls below 9V, thereby protecting the system from deep discharge conditions. To enhance usability and operational awareness, the system integrates Wi-Fi-based communication for remote monitoring and notification through a mobile device. The proposed model demonstrates a comprehensive approach that combines renewable energy utilization, digital protection, and remote supervisory control. The results indicate improved sustainability, enhanced safety, and reliable motor operation, making the system suitable for industrial and commercial applications. This work highlights the potential of intelligent, energy-efficient motor control solutions for modern engineering systems.

Keywords: Digital Protection, Remote Monitoring, Pulse Width Modulation, Solar Powered Battery, Linear Speed Control

I. INTRODUCTION

The growing demand for sustainable and reliable energy solutions has significantly increased the adoption of renewable energy sources, particularly solar photovoltaic (PV) systems. Solar energy offers an environmentally friendly and abundant source of power that can be effectively utilized for driving electrical loads such as induction motors in agricultural, industrial, and remote applications. Induction motors are widely used due to their robust construction, low maintenance requirements, and high reliability. However, when powered by solar energy, variations in solar irradiance and environmental conditions can lead to fluctuations in voltage and current, which may affect motor performance and safety. To ensure efficient operation and longevity of solar-powered induction motors, continuous monitoring and effective protection mechanisms are essential. Traditional monitoring systems often require manual supervision and lack real-time accessibility, making fault detection and system management more difficult. With the advancement of Internet of Things (IoT) technologies, wireless communication platforms such as Wi Fi have become effective tools for remote monitoring and intelligent control of electrical systems. A Wi Fi-enabled monitoring and control system allows real-time observation of key motor parameters such as voltage, current, temperature, and operational status through internet-connected devices. This enables operators to detect abnormal conditions, implement protective measures, and



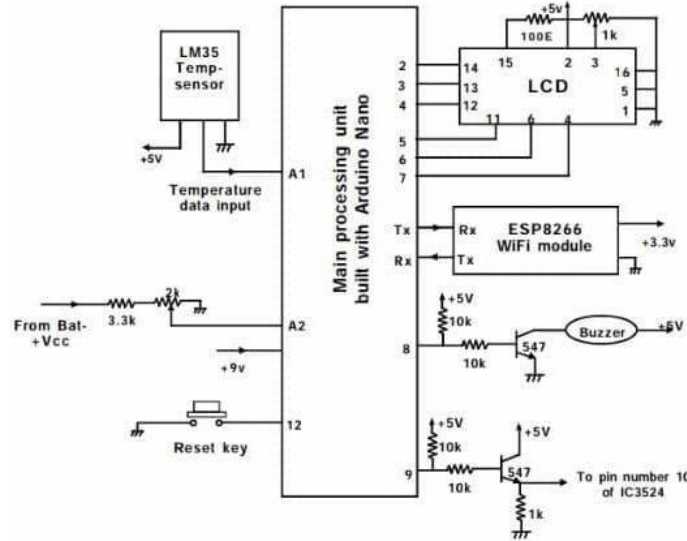

Fig.03 Block Diagram of Wifi Enabled Monitoring, Control and Protection of Solar Fed Induction Motor-Part-02

V. PROPOSED SYSTEM



Fig04: Prototype displaying voltage and temperature



Fig05: Prototype turned off automatically due to low voltage





Fig06: Prototype turned off automatically due to high temperature



Fig07: Output shown in the mobile via wifi showing temperature and voltage



Fig08: Output shown in the mobile via wifi showing temperature and low voltage alert





Fig09: Output shown in the mobile via wifi showing high temperature alert and voltage

VI. RESULTS AND DISCUSSION

The experimental results demonstrate that the proposed system provides an effective solution for intelligent monitoring and protection of solar-fed induction motors. The integration of renewable energy with IoT- based monitoring enhances operational efficiency and improves system reliability. The ESP8266 module provides a low-cost and efficient communication platform for implementing real-time monitoring and remote control functions. The proposed architecture is particularly suitable for rural and off-grid applications where solar-powered motor systems are widely used. By enabling remote supervision and automatic protection, the system reduces maintenance effort and improves the overall safety of motor operations.

VII. FUTURE SCOPE

The proposed system can be further enhanced by integrating cloud-based IoT platforms for data storage, analysis, and predictive maintenance. The use of Maximum Power Point Tracking (MPPT) techniques can improve solar energy utilization and system efficiency. Additional sensors such as vibration and speed sensors can be incorporated for advanced motor health monitoring. A mobile application interface can also be developed for easier user interaction and real-time alerts. Furthermore, the system can be expanded for large-scale smart agriculture and industrial motor control applications.

VIII. CONCLUSION

The developed system demonstrates an effective approach for monitoring, controlling, and protecting an induction motor powered by solar energy using a WiFi-based communication platform. The architecture integrates solar power generation, sensing circuits, embedded control, and wireless communication to enable real-time observation of key operational parameters. The monitoring system allows users to access motor status and electrical measurements remotely, improving system visibility and operational convenience.

REFERENCES

- [1]. A. A. Musyafiq, S. D. Utomo, and F. Nugroho, "IoT-based control, monitoring, and protection system for 3-phase induction motors in electric motorcycles," *Journal of Power, Energy, and Control*, vol. 1, no. 2, pp. 14–22, 2024, doi: 10.62777/pec.v1i2.32.



- [2]. A. Marzuki, H. Setiawan, and M. Y. Firdaus, "Three-phase induction motor control and monitoring using VFD and ESP32 based on Modbus RTU protocol," American Journal of Electrical and Computer Engineering, vol. 8, no. 2, pp. 71–80, 2024, doi: 10.11648/j.ajece.20240802.15.
- [3]R. S. Putra, W. B. Fanani, and A. Hadi, "Design and implementation of an IoT-based speed control and monitoring system for 3-phase induction motors," SAINSTECH NUSANTARA, vol. 2, no. 3, pp. 67–75, 2025, doi: 10.71225/jstn.v2i3.84.
- [4]M. Hassan, S. Iqbal, and A. Rashid, "Design and evaluation of an IoT-based induction motor protection and control system using Arduino and ESP32," International Journal of Electrical Systems, vol. 21, no. 1, pp. 35–44, 2025.

