

# **GSM-Based Accident Detection System**

**Prof. S. R. Chaudhari, Mr. Prasanna R Shrungare, Nishant Pathak**

Lecturer, Electronics and Telecomm Engg Department

Students, Electronics and Telecomm Engg Department

Dr Rajendra Gode Institute of Tech and Research, Amravati, India

**Abstract:** *Traffic dangers and road accidents have been on the rise due to the growing demand for vehicles. The lives of the people are in grave danger. The likelihood of the victim's death increases due to the traffic congestion between the accident site and the hospital as well as the delay in the emergency assistance. Our automated rescue system steps in to help us solve this difficulty. Both the number of lives lost in accidents and the amount of time it takes for an ambulance to get to the hospital can be alleviated with the aid of this suggested IoT-based accident detection system. The GSM-Based Accident Detection System is an IoT-enabled smart solution designed to enhance road safety and provide timely emergency alerts. The system integrates multiple sensors with a NodeMCU. Controller to automatically detect accidents and hazardous situations such as fire or collisions. A Gyro sensor monitors sudden vehicle tilts or abnormal movements, while a bumper sensor detects collisions. The MQ sensor is used to detect fire or smoke inside the vehicle, preventing potential hazards. The GPS module tracks the exact location of the vehicle in real-time, and the Blynk app provides instant notifications to vehicle owners or emergency contacts when an accident occurs. By automating accident detection and alerting mechanisms, this system minimizes human intervention, reduces response time for rescue operations, and enhances overall road and vehicle safety. The project is particularly beneficial in emergency situations where immediate medical or rescue assistance is critical.*

**Keywords:** *Traffic*

## **I. INTRODUCTION**

While most accidents in cities can be quickly and easily handled by emergency services, it can be difficult to pinpoint the exact location of an accident. The distance from the scene of the accident to the hospital can be cut in half if the driver is aware of the exact location. In the event of an accident, this paper's primary goal is to assist in decreasing the time factor. Many accidents happen at night, and if the victim is unconscious, it can take hours before someone discovers the accident and reports it to the authorities. Therefore, lives will be saved by preserving this valuable time. In keeping with this idea, we build an experimental system that can identify accidents autonomously, without the need for human intervention. The system uses a combination of sensors and IoT technology to automatically detect accidents and hazardous situations in real-time. Sensors such as the Gyro sensor and bumper sensor detect collisions, vehicle tilts, and abnormal movements, while the MQ sensor identifies smoke or fire inside the vehicle. The GPS module provides precise vehicle location, and the Blynk app allows instant notification to emergency contacts and vehicle owners. By automating accident detection and alerts, the system ensures faster rescue operations, reduces human dependency, and enhances overall road safety, making it an essential solution for modern transportation.

## **II. RESEARCH METHODOLOGY**

### **PROPOSED SYSTEM**

The proposed system for the GSM-Based Accident Detection System follows a systematic approach to design, develop, and validate an IoT-based smart safety solution. The system architecture is designed, integrating NodeMCU as the central controller with multiple sensors including MQ for fire detection, Gyro for tilt and accident detection, and bumper sensors for collision detection, along with a GPS module for real-time vehicle location tracking. The hardware



implementation involves connecting and calibrating these sensors with the NodeMCU to ensure accurate detection of accidents and hazardous conditions. In the software development phase, Arduino IDE is used to program the NodeMCU for reading sensor inputs, processing accident logic, and transmitting real-time data to the BlynkIoT platform, which displays notifications and alerts on a mobile app. This methodology ensures the development of a comprehensive, multi-hazard, and real-time accident detection system capable of minimizing human intervention and saving lives.

**BLOCK DIAGRAM**

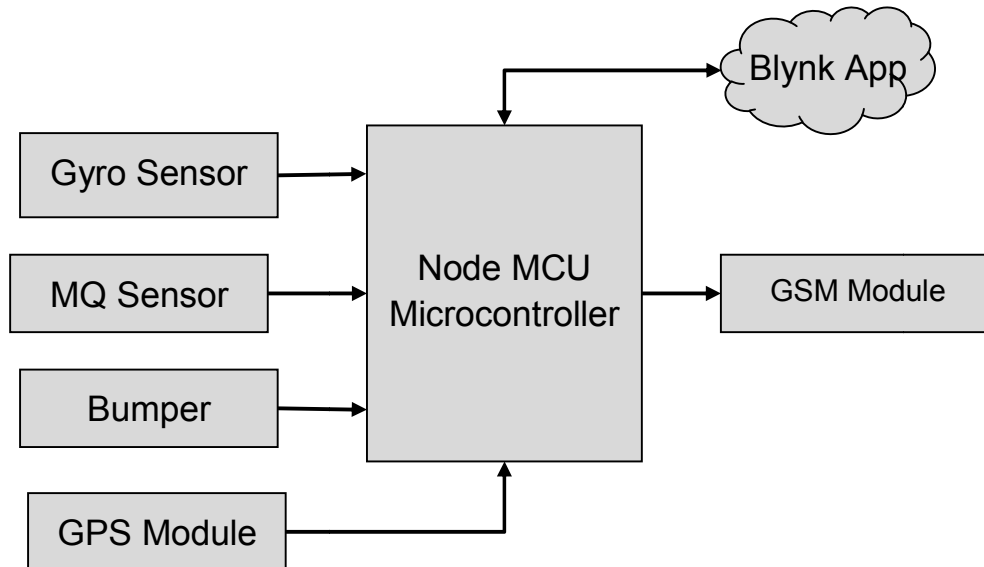

Fig. Shows the block diagram of the system

**DESCRIPTION**

In this we have used Node MCU Microcontroller, In input we have Gyro Sensor, MQ Sensor, Bumper Sensor, GPS module. In output we have a GSM Module. We have used the Blynk App to show all the notifications.

**FLOW CHART**

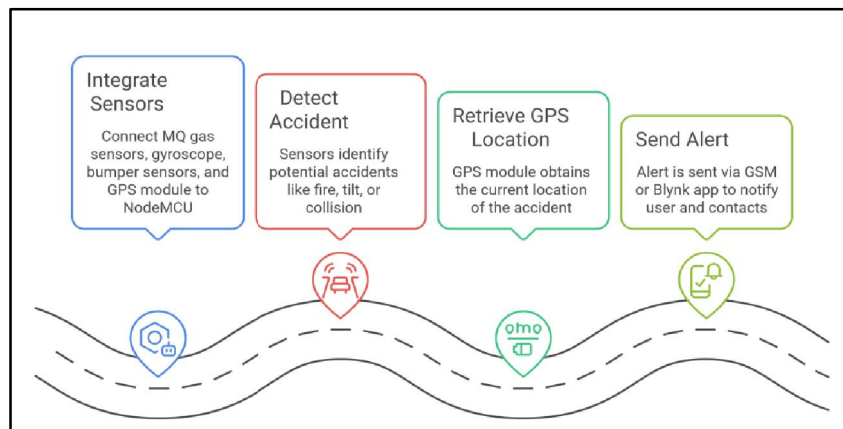

Fig. Shows the flow chart of the system



### **WORKING**

The GSM-Based Accident Detection System works by continuously monitoring vehicle conditions using multiple sensors connected to a NodeMCU controller. When the system is powered on, the NodeMCU initializes the MQ fire sensor, gyro sensor, bumper sensor, and GPS module. These sensors continuously send real-time data to the controller. If the bumper sensor detects a sudden impact, the gyro sensor detects abnormal tilt or rollover, or the MQ sensor detects fire or gas leakage beyond a threshold level, the NodeMCU identifies it as an accident or hazardous event. Immediately, the controller reads the current GPS coordinates of the vehicle and prepares an emergency alert message. This alert is then transmitted through GSM/IoT connectivity to the Blynk mobile application and registered contacts. The user and emergency responders receive instant notifications along with location details, enabling quick rescue action without requiring manual reporting.

### **III. SYSTEM REQUIREMENT**

#### **HARDWARE REQUIREMENT**

- Node MCU Microcontroller
- GPS Module
- GSM Module
- Gyro Sensor
- MQ Sensor
- Bumper Sensor

#### **SOFTWARE REQUIREMENT**

- Arduino IDE
- Proteus
- Blynk Module

### **WORKING**

The GSM-Based Accident Detection System works by continuously monitoring vehicle conditions using multiple sensors connected to a NodeMCU controller. When the system is powered on, the NodeMCU initializes the MQ fire sensor, gyro sensor, bumper sensor, and GPS module. These sensors continuously send real-time data to the controller. If the bumper sensor detects a sudden impact, the gyro sensor detects abnormal tilt or rollover, or the MQ sensor detects fire or gas leakage beyond a threshold level, the NodeMCU identifies it as an accident or hazardous event. Immediately, the controller reads the current GPS coordinates of the vehicle and prepares an emergency alert message. This alert is then transmitted through GSM/IoT connectivity to the Blynk mobile application and registered contacts. The user and emergency responders receive instant notifications along with location details, enabling quick rescue action without requiring manual reporting.

### **NODE MCU**

The NodeMCU (Node MicroController Unit) is an open source software and hardware development environment that is built around a very inexpensive System-on-a-Chip (SoC) called the ESP8266.



The ESP8266, designed and manufactured by Espressif Systems, contains all crucial elements of the modern computer: CPU, RAM, networking (wifi), and even a modern operating system and SDK. When purchased at bulk, the ESP8266 chip costs only \$2 USD a piece. That makes it an excellent choice for IoT projects of all kinds.

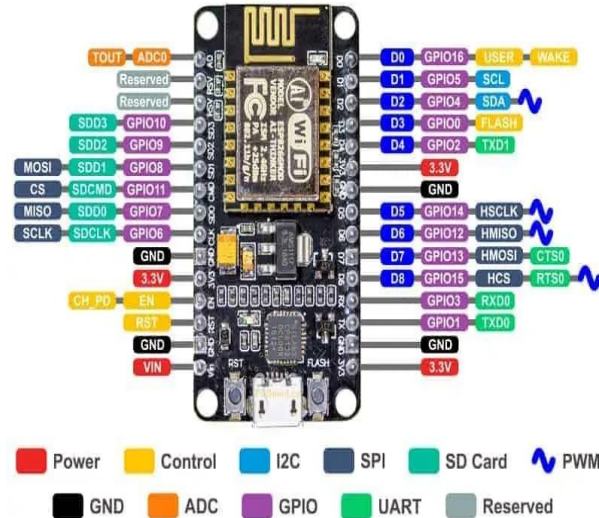

Through its pins we can read inputs - light on a sensor, a finger on a button, or a Twitter message -and turn them into an output - activating a motor, turning on an LED, publishing something online. It has also WiFi capabilities, so we can control it wirelessly and make it work on a remote installation easily! We can tell our board what to do by sending a set of instructions to the microcontroller on the board. To do so we can use the Arduino Software (IDE).

**Power Pins** There are four power pins. VIN pin and three 3.3V pins.

VIN can be used to directly supply the NodeMCU/ESP8266 and its peripherals. Power delivered on VIN is regulated through the onboard regulator on the NodeMCU module – you can also supply 5V regulated to the VIN pin

3.3V pins are the output of the onboard voltage regulator and can be used to supply power to external components.

GND are the ground pins of NodeMCU/ESP8266

**I2C Pins** are used to connect I2C sensors and peripherals. Both I2C Master and I2C Slave are supported. I2C interface functionality can be realized programmatically, and the clock frequency is 100 kHz at a maximum. It should be noted that I2C clock frequency should be higher than the slowest clock frequency of the slave device.

**GPIO Pins** NodeMCU/ESP8266 has 17 GPIO pins which can be assigned to functions such as I2C, I2S, UART, PWM, IR Remote Control, LED Light and Button programmatically. Each digital enabled GPIO can be configured to internal pull-up or pull-down, or set to high impedance. When configured as an input, it can also be set to edge-trigger or level-trigger to generate CPU interrupts.

**ADC Channel** The NodeMCU is embedded with a 10-bit precision SAR ADC. The two functions can be implemented using ADC. Testing power supply voltage of VDD3P3 pin and testing input voltage of TOUT pin. However, they cannot be implemented at the same time.

**UART Pins** NodeMCU/ESP8266 has 2 UART interfaces (UART0 and UART1) which provide asynchronous communication (RS232 and RS485), and can communicate at up to 4.5 Mbps. UART0 (TXD0, RXD0, RST0 & CTS0 pins) can be used for communication. However, UART1 (TXD1 pin) features only data transmit signal so, it is usually used for printing log.

**SPI Pins** NodeMCU/ESP8266 features two SPIs (SPI and HSPI) in slave and master modes. These SPIs also support the following general-purpose SPI features:

4 timing modes of the SPI format transfer



Up to 80 MHz and the divided clocks of 80 MHz

Up to 64-Byte FIFO

SDIO Pins NodeMCU/ESP8266 features Secure Digital Input/Output Interface (SDIO) which is used to directly interface SD cards. 4-bit 25 MHz SDIO v1.1 and 4-bit 50 MHz SDIO v2.0 are supported.

PWM Pins The board has 4 channels of Pulse Width Modulation (PWM). The PWM output can be implemented programmatically and used for driving digital motors and LEDs. PWM frequency range is adjustable from 1000  $\mu$ s to 10000  $\mu$ s (100 Hz and 1 kHz).

Control Pins are used to control the NodeMCU/ESP8266. These pins include Chip Enable pin (EN), Reset pin (RST) and WAKE pin.

EN: The ESP8266 chip is enabled when EN pin is pulled HIGH. When pulled LOW the chip works at minimum power.

RST: RST pin is used to reset the ESP8266 chip.

WAKE: Wake pin is used to wake the chip from deep-sleep.

Control Pins are used to control the NodeMCU/ESP8266. These pins include Chip Enable pin (EN), Reset pin (RST) and WAKE pin.

EN: The ESP8266 chip is enabled when EN pin is pulled HIGH. When pulled LOW the chip works at minimum power.

RST: RST pin is used to reset the ESP8266 chip.

WAKE: Wake pin is used to wake the chip from deep-sleep.

NodeMCU ESP8266 Specifications & Features

Microcontroller: Tensilica 32-bit RISC CPU Xtensa LX106

Operating Voltage: 3.3V

Input Voltage: 7-12V

Digital I/O Pins (DIO): 16

Analog Input Pins (ADC): 1

UARTs: 1

SPIs: 1

I2Cs: 1

Flash Memory: 4 MB

SRAM: 64 KB

Clock Speed: 80 MHz

USB-TTL based on CP2102 is included onboard, Enabling Plug n Play

PCB Antenna

Small Sized module to fit smartly inside your IoT projects

Applications

Prototyping of IoT devices

Low power battery operated applications

Network projects

Projects requiring multiple I/O interfaces with Wi-Fi and Bluetooth functionalities

**GPS**

### **NEO - 6M GPS MODULE**

The global positioning system (GPS) is a network of satellites and receiving devices used to determine the location of something on Earth. GPS receivers provide location in latitude, longitude, and altitude.





**SPECIFICATION**

- 5Hz position update rate
- Operating temperature range: -40 TO 85°C UART TTL socket
- EEPROM to save configuration settings
- Rechargeable battery for Backup
- The cold start time of 38 s and Hot start time of 1 s
- Supply voltage: 3.3 V
- Configurable from 4800 Baud to 115200 Baud rates. (default 9600)
- SuperSense® Indoor GPS: -162 dBm tracking sensitivity
- Support SBAS (WAAS, EGNOS, MSAS, GAGAN)
- Separated 18X18mm GPS antenna

**NEO 6M PINOUT**

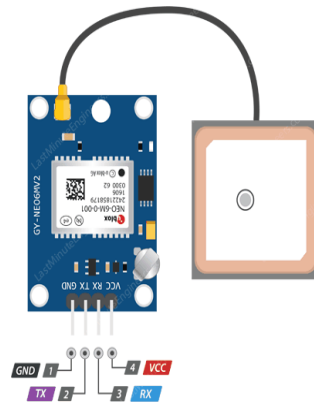

Pin Name	Description
VCC	Positive power pin
RX	UART receive pin



TX	UART transmit pin
GND	Ground

### GSM

The **SIM800L** is a GSM module from Simcom that gives any microcontroller GSM functionality, meaning it can connect to the mobile network to receive calls and send and receive text messages, and also connect to the internet using GPRS, TCP, or IP. Another advantage is that the board makes use of existing mobile frequencies, which means it can be used anywhere in the World

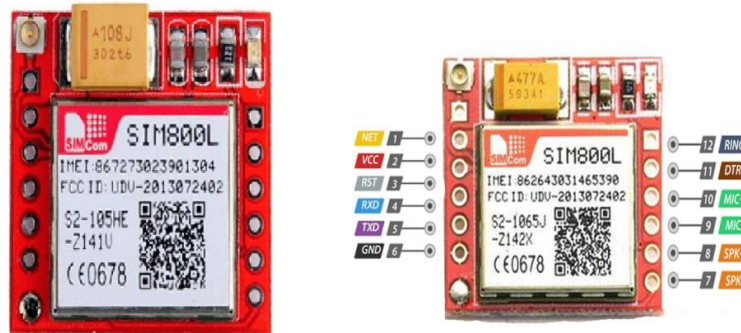

Pinout diagram

### Applications

- Home automation
- Emergency systems
- Remote sensing
- Communication
- Features and Specifications
- Full modem serial port
- Two microphone inputs and speaker output
- SIM card interface
- Supports FM and PWM
- Sleep mode with 0.7mA current

### Gyro sensor

A gyroscope sensor is a device that can measure and maintain the orientation and angular velocity of an object. These are more advanced than accelerometers. These can measure the tilt and lateral orientation of the object whereas accelerometer can only measure the linear motion.

Gyroscope sensors are also called as Angular Rate Sensor or Angular Velocity Sensors. These sensors are installed in the applications where the orientation of the object is difficult to sense by humans.

Measured in degrees per second, angular velocity is the change in the rotational angle of the object per unit of time.



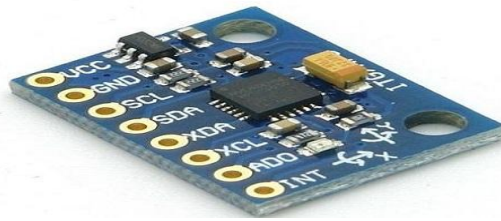

## **Gyroscope Sensor**

### **Working Principle**

Besides sensing the angular velocity, Gyroscope sensors can also measure the motion of the object. For more robust and accurate motion sensing, in consumer electronics Gyroscope sensors are combined with Accelerometer sensors.

Depending on the direction there are three types of angular rate measurements. Yaw- the horizontal rotation on a flat surface when seen the object from above, Pitch- Vertical rotation as seen the object from front, Roll- the horizontal rotation when seen the object from front.

The concept of Coriolis force is used in Gyroscope sensors. In this sensor to measure the angular rate, the rotation rate of the sensor is converted into an electrical signal. Working principle of Gyroscope sensor can be understood by observing the working of Vibration Gyroscope sensor. This sensor consists of an internal vibrating element made up of crystal material in the shape of a double – T- structure. This structure comprises a stationary part in the center with ‘Sensing Arm’ attached to it and ‘Drive Arm’ on both sides.

This double-T-structure is symmetrical. When an alternating vibration electrical field is applied to the drive arms, continuous lateral vibrations are produced. As Drive arms are symmetrical, when one arm moves to left the other moves to the right, thus canceling out the leaking vibrations. This keeps the stationary part at the center and the sensing arm remains static.

When the external rotational force is applied to the sensor vertical vibrations are caused on Drive arms. This leads to the vibration of the Drive arms in the upward and downward directions due to which a rotational force acts on the stationary part in the center.

Rotation of the stationary part leads to the vertical vibrations in sensing arms. These vibrations caused in the sensing arm are measured as a change in electrical charge. This change is used to measure the external rotational force applied to the sensor as Angular rotation.

### **Types**

With the advance in technology highly accurate, reliable and miniature devices are being manufactured. More accurate measurements of orientation and movement in a 3D space became possible with the integration of the Gyroscope sensor. Gyroscopes are also available in different sizes with different performances.

Based on their sizes, Gyroscope sensors are divided as small and large-sized. From large to small the hierarchy of Gyroscope sensors can be listed as Ring laser gyroscope, Fiber-optic gyroscope, Fluid gyroscope, and Vibration gyroscope.

Being small and more easy to use Vibration gyroscope is most popular. The accuracy of vibration gyroscope depends upon the stationary element material used in the sensor and structural differences. So, manufacturers are using different materials and structures to increase the accuracy of vibration gyroscope.

### **Application**

Gyroscope Sensors are used for versatile applications. Ring laser Gyros are used in Aircraft and Source shuttles whereas Fiber optic Gyros are used in racecars and motorboats.



Vibration Gyroscope sensors are used in the car navigation systems, Electronic stability control systems of vehicles, motion sensing for mobile games, camera-shake detection systems in digital cameras, radio-controlled helicopters, Robotic systems, etc...

The main functions of the Gyroscope Sensor for all the applications are Angular velocity sensing, angle sensing, and control mechanisms. Image blurring in cameras can be compensated by using Gyroscope Sensor-based optical image stabilization system.

By understanding their behavior and characteristics developers are designing many efficient and low-cost products such as gesture-based control of the wireless mouse, directional control of wheel-chair, a system to control external devices using gesture commands, etc...

### **MQ2 gas sensor**

MQ2 gas sensor is an electronic sensor used for sensing the concentration of gases in the air such as LPG, propane, methane, hydrogen, alcohol, smoke, and carbon monoxide.

MQ2 gas sensor is also known as chemiresistor. It contains a sensing material whose resistance changes when it comes in contact with the gas. This change in the value of resistance is used for the detection of gas.



MQ2 is a metal oxide semiconductor type gas sensor. Concentrations of gas in the gas is measured using a voltage divider network present in the sensor. This sensor works on 5V DC voltage. It can detect gasses in the concentration of 200 to 10000ppm.

### **Working Principle**

This sensor contains a sensing element, mainly aluminum-oxide based ceramic, coated with Tin dioxide, enclosed in a stainless steel mesh. Sensing element has six connecting legs attached to it. Two leads are responsible for heating the sensing element, the other four are used for output signals.

Oxygen gets adsorbed on the surface of sensing material when it is heated in air at high temperature. Then donor electrons present in tin oxide are attracted towards this oxygen, thus preventing the current flow.

When reducing gasses are present, these oxygen atoms react with the reducing gasses thereby decreasing the surface density of the adsorbed oxygen. Now current can flow through the sensor, which generates analog voltage values.

These voltage values are measured to know the concentration of gas. Voltage values are higher when the concentration of gas is high.

### **Applications**

These sensors are used to detect the presence of gasses in the air such as methane, butane, LPG and smoke but they are unable to distinguish between gasses. Thus, they cannot tell which gas it is.

Module version of this sensor can be used without interfacing to any microcontroller and is useful when detecting only one particular gas. This can only detect the gas. But if ppm has to be calculated then the sensor should be used without a module



### Bumper Sensor

The bump sensors (bump switch) are used on our robot kit 10004, and it can help the robot kit avoid obstacles and move on the no obstacles path. Bump sensors (bump switch) let your robot kit sense contact. For example, use a bump sensor (bump switch) to sense contact over a larger area in front of the robot.

The bump sensors (bump switch) are digital sensors with a robot program to perform various tasks. The bump sensor (bump switch) can detect and avoid obstacles. Use a bump sensor (bump switch) in front of your robot kit with a bit of code. The robot can back up and turn around to avoid dangerous collisions autonomously; this is the benefit of using a bump sensor (bump switch) with your robot programming.



### Specifications

Dimension: 105mm X 33mm X 25mm

Body Material: Aluminium Alloy

Net Weight: 45g

Key Features

Provide feedback to Microcontroller as events “happen.”

Rugged bumpers allow the switch to be triggered without damage.

Useful as a trigger in a variety of applications.

Functionality is pre-programmed in the NEXUS Microcontroller

### Arduino IDE Software Intro

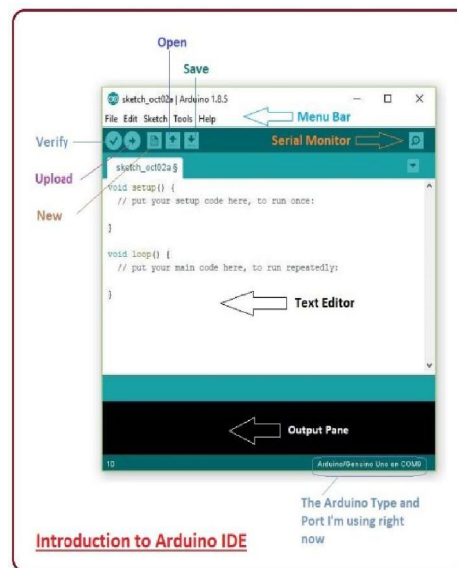

Fig shows the home page of arduino IDE



An official software introduced by Arduino.cc, that is mainly used for writing, compiling and uploading the code in almost all Arduino modules/boards. Arduino IDE is open-source software and is easily available to download & install. **Arduino IDE** is an open-source software, designed by Arduino.cc and mainly used for writing, compiling & uploading code to almost all Arduino Modules.

It is an official Arduino software, making code compilation too easy that even a common person with no prior technical knowledge can get their feet wet with the learning process.

It is available for all operating systems i.e. MAC, Windows, Linux and runs on the Java Platform that comes with inbuilt functions and commands that play a vital role in debugging, editing and compiling the code.

A range of Arduino modules available including Arduino Uno, Arduino Mega, Arduino Leonardo, Arduino Micro and many more.

Each of them contains a microcontroller on the board that is actually programmed and accepts the information in the form of code.

The main code, also known as a sketch, created on the IDE platform will ultimately generate a Hex File which is then transferred and uploaded in the controller on the board.

The IDE environment mainly contains two basic parts: Editor and Compiler where the former is used for writing the required code and later is used for compiling and uploading the code into the given Arduino Module.

This environment supports both C and C++ languages.

File	
<b>New</b>	This is used to open new text editor window to write your code
<b>Open</b>	Used for opening the existing written code
<b>Open Recent</b>	The option reserved for opening recently closed program
<b>Sketchbook</b>	It stores the list of codes you have written for your project
<b>Examples</b>	Default examples already stored in the IDE software
<b>Close</b>	Used for closing the main screen window of recent tab. If two tabs are open, it will ask you again as you aim to close the second tab
<b>Save</b>	It is used for saving the recent program
<b>Save as</b>	It will allow you to save the recent program in your desired folder
<b>Page setup</b>	Page setup is used for modifying the page with portrait and landscape options. Some default page options are already given from which you can select the page you intend to work on
<b>Print</b>	It is used for printing purpose and will send the command to the printer
<b>Preferences</b>	It is page with number of preferences you aim to setup for your text editor page
<b>Quit</b>	It will quit the whole software all at once

Fig shows the Files in Arduino IDE

As you go to the preference section and check the compilation section, the Output Pane will show the code compilation as you click the upload button.



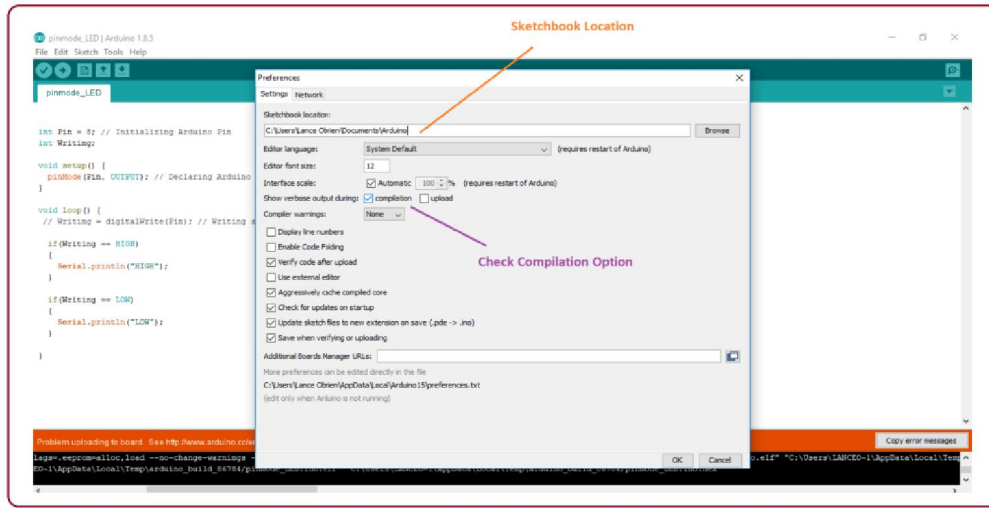

Fig shows the Compilation option in Arduino IDE

And at the end of the compilation, it will show you the hex file it has generated for the recent sketch that will send to the Arduino Board for the specific task you aim to achieve.



Fig shows the Hex File Generated in Arduino IDE

**Edit** – Used for copying and pasting the code with further modification for font

**Sketch** – For compiling and programming

**Tools** – Mainly used for testing projects. The Programmer section in this panel is used for burning a bootloader to the new microcontroller.

**Help** – In case you are feeling skeptical about software, complete help is available from getting started to troubleshooting.

The **Six Buttons** appearing under the Menu tab are connected with the running program as follows.

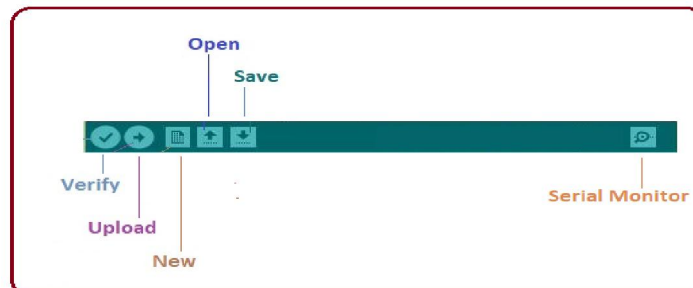

The checkmark appearing in the circular button is used to verify the code. Click this once you have written your code.

The arrow key will upload and transfer the required code to the Arduino board.

The dotted paper is used for creating a new file.



The upward arrow is reserved for opening an existing Arduino project.

The downward arrow is used to save the current running code.

The button appearing on the top right corner is a **Serial Monitor** – A separate pop-up window that acts as an independent terminal and plays a vital role in sending and receiving the Serial Data. You can also go to the Tools panel and select Serial Monitor, or pressing Ctrl+Shift+M all at once will open it instantly. The Serial Monitor will actually help to debug the written Sketches where you can get a hold of how your program is operating. Your Arduino Module should be connected to your computer by USB cable in order to activate the Serial Monitor.

You need to select the baud rate of the Arduino Board you are using right now. For my Arduino Uno Baud Rate is 9600, as you write the following code and click the Serial Monitor, the output will show as the image below.

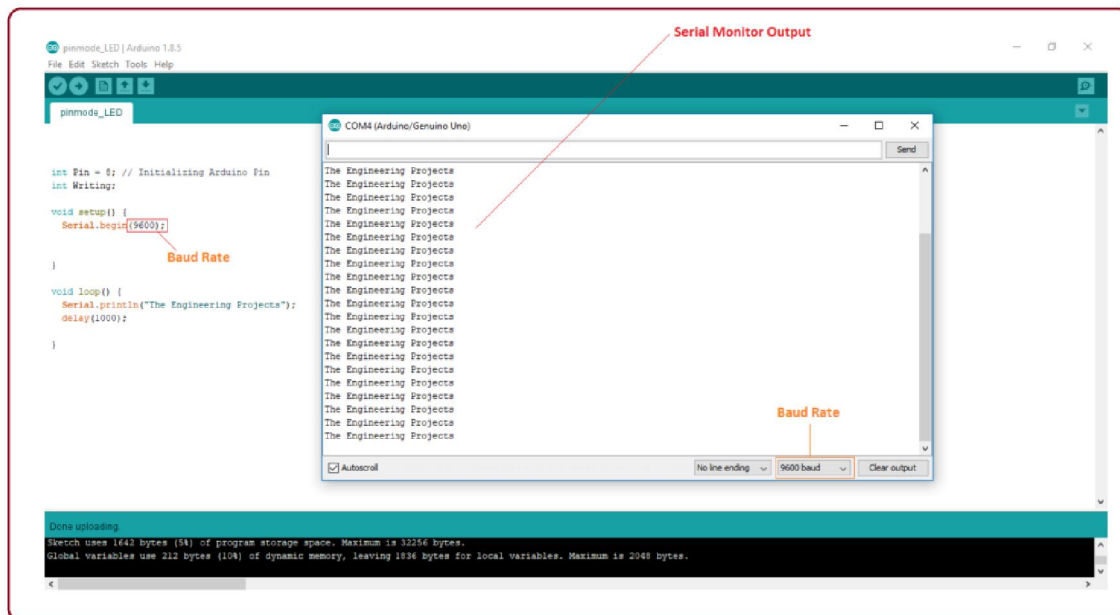

## PROTEUS

It is a software suite containing schematic, simulation as well as PCB designing.

ISIS is the software used to draw schematics and simulate the circuits in real-time. The simulation allows human access during run time, thus providing real-time simulation.

ARES is used for PCB designing. It has the feature of viewing the output in 3D view of the designed PCB along with components.

The designer can also develop 2D drawings for the product.

### Features

ISIS has a wide range of components in its library. It has sources, signal generators, measurement and analysis tools like oscilloscope, voltmeter, ammeter, etc., probes for real-time monitoring of the parameters of the circuit, switches, displays, loads like motors and lamps, discrete components like resistors, capacitors, inductors, transformers, digital and analog Integrated circuits, semiconductor switches, relays, microcontrollers, processors, sensors, etc.

ARES offers PCB designing up to 14 inner layers, with surface mount and through-hole packages. It is embedded with the footprints of different categories of components like ICs, transistors, headers, connectors, and other discrete components. It offers Auto routing and manual routing options to the PCB Designer. The schematic drawing in ISIS can be directly transferred to ARES.



## Blynk Application

Blynk is an IoT platform for iOS or Android smartphones that is used to control Arduino, Raspberry Pi and NodeMCU via the Internet. This application is used to create a graphical interface or human machine interface (HMI) by compiling and providing the appropriate address on the available widgets.

Blynk was designed for the Internet of Things. It can control hardware remotely, it can display sensor data, it can store data, visualize it and do many other cool things.

There are three major components in the platform .

**Blynk App:** – It allows you to create amazing interfaces for your projects using various widgets which are provided.



**The Blynk Platform: smartphone app**

- The app is really an app editor.
- Use it to create Blynk projects.
- Each project may contain multiple widgets and connect to multiple devices.
- Projects are shareable.

**Blynk Server:** – It is responsible for all the communications between the smartphone and hardware.

You can use the Blynk Cloud or run your private Blynk server locally. It's open-source, could easily handle thousands of devices and can even be launched on a Raspberry Pi.

**Blynk Libraries:** – It enables communication, for all the popular hardware platforms, with the server and processes all the incoming and outgoing commands.

The process that occurs when someone presses the Button in the Blynk application is that the data will move to Blynk Cloud, where data magically finds its way to the hardware that has been installed. It works in the opposite direction and everything happens in the blink of an eye .

## ADVANTAGES

**Automatic Accident Detection** – The system automatically detects accidents, collisions, or vehicle tilts without requiring manual intervention, ensuring faster response.

**Real-Time Alerts** – Integration with the Blynk app and GSM module allows instant notifications to vehicle owners and emergency contacts, reducing rescue response time.

**Multi-Hazard Detection** – Using Gyro, bumper, and MQ sensors, the system can detect accidents, collisions, and fire hazards simultaneously, improving overall safety.

**Accurate Vehicle Location** – The GPS module provides precise real-time location, enabling emergency services to reach the accident site quickly.

**Reduced Human Dependency** – Automation eliminates the need for witnesses or manual reporting, minimizing delays in alerting authorities.

## APPLICATIONS

Used in cars and two-wheelers for automatic accident detection.

Helps in commercial vehicles and trucks for driver safety monitoring.

Suitable for school buses to ensure student transport safety.



Applied in fleet management systems for real-time vehicle tracking and alerts.  
Sends instant emergency notifications to family and rescue teams.  
Useful on highways for rapid accident reporting and response.  
Effective in remote and hilly areas where quick help is difficult to access.

## V. EXPERIMENTAL SETUP & RESULT

### EXPERIMENTAL SETUP



**Fig. 7 (i) Shows the Hardware Setup of the Proposed System**



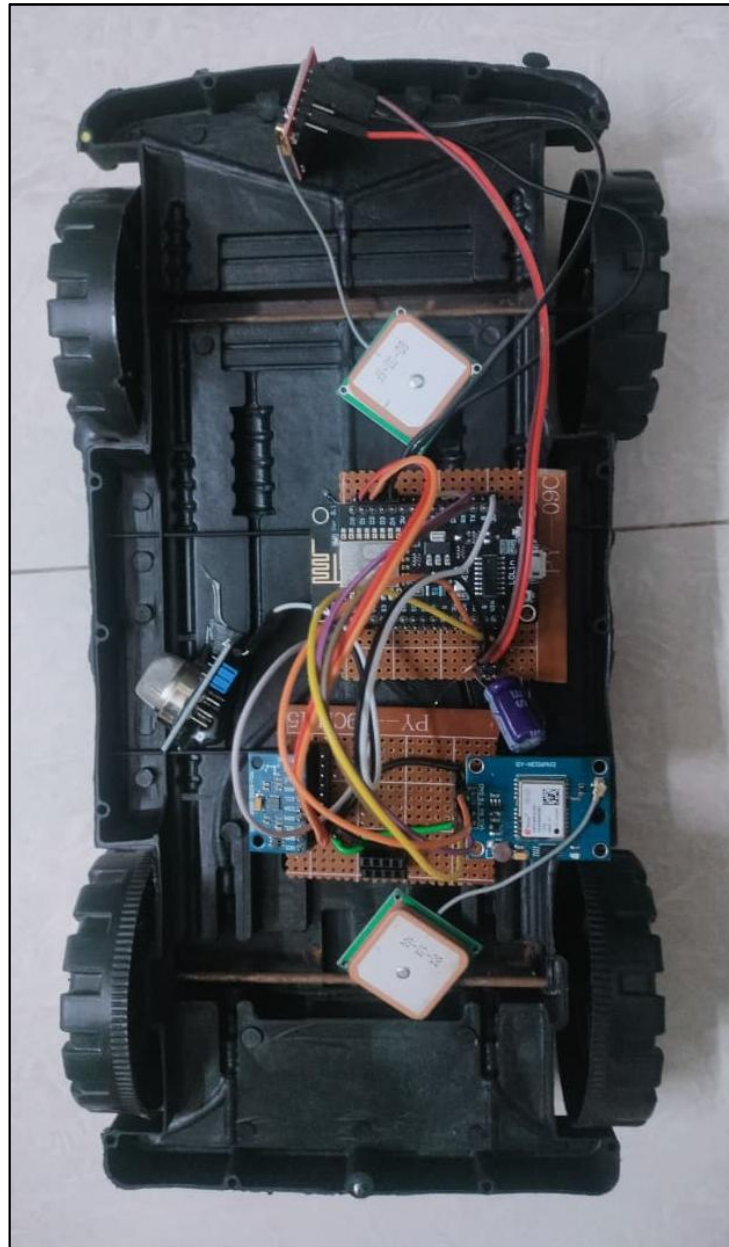

**Fig. 7 (ii) Shows the Hardware Setup of the Proposed System**

## RESULT

The result of the project shows that the system is able to detect accident situations effectively and send alerts in a short time. During testing, the gyro sensor and bumper sensor successfully identified sudden impacts and unusual vehicle movements that indicate an accident. As soon as such a condition was detected, the system quickly collected the vehicle's location through the GPS module and sent an alert message. The notification was also received on the Blynk application, which made it easy to monitor the situation. In addition, the MQ sensor was able to sense smoke or gas that



could occur after an accident. Overall, the system responded quickly and showed that it can help inform others about an accident without delay, which may help in getting faster assistance during emergencies.

## **VI. CONCLUSION & FUTURE SCOPE**

### **CONCLUSION**

The GSM-Based Accident Detection System is an effective IoT-enabled solution designed to enhance road safety and minimize delays in emergency response. By integrating multiple sensors, including Gyro, bumper, and MQ fire sensors, with NodeMCU, GPS, and GSM modules, the system can detect accidents, collisions, and fire hazards in real-time. Alerts are instantly sent to vehicle owners and emergency contacts via the Blynk app and GSM messages, ensuring timely assistance. This automated approach reduces human intervention, improves rescue efficiency, and provides accurate vehicle location information for rapid emergency response. Overall, the project demonstrates a practical and cost-effective method to enhance vehicle safety, save lives, and reduce accident-related damages, making it a valuable tool for modern transportation safety systems.

### **FUTURE SCOPE**

The future scope of the GSM-Based Accident Detection System is very broad and can be enhanced with advanced IoT and AI technologies to improve accuracy and response speed. In the future, the system can be integrated with an ESP32-CAM module to automatically capture images or short videos at the time of an accident and send them to emergency services for better situation assessment. Artificial Intelligence and Machine Learning algorithms can be added to analyze driving patterns and predict possible accident risks before they occur. The system can also be connected directly with hospital and ambulance networks to enable automatic dispatch of emergency services. Cloud integration will allow large-scale storage and analysis of accident data for safety research and traffic planning. Additional biometric sensors can be used to monitor driver health and fatigue levels. With the adoption of 5G and smart transportation infrastructure, the system can support vehicle-to-vehicle and vehicle-to-infrastructure communication, making accident detection and response more intelligent, faster, and more reliable.

## **REFERENCES**

- [1]. AlokBeheramali, SubhenduSekharSahoo. "Accident Detection And Alert System GPS & GSM On IOT Based". Advances in Applied Science Research . April 2023.
- [2]. HarshadaDattatrayHajare, GauriMarutiBansode, AnujaDevanandKhandekar , Rahul Krishna Patole. "GSM/GPS BASED VEHICLE ACCIDENT ALERT SYSTEM USING NODE MCU ". IJPREMS Vol. 04, Issue 05, May 2024.
- [3]. Prof. C. S. Tikhe, AmolSarode, AniketKharat, AashutoshDalavi, Akash Mule, Dinesh Bhalerao. "IOT based Accident Alert and Vehicle Tracking using GPS and GSM module". IJARSCT Volume 3, Issue 2, April 2023.
- [4]. R.Manish, M. Sumithra, Lokhitha D., Mahalakshmi L., Durga V., Nirmala G. "Accident Detection System Using GPS and GSM by IOT". JHCI vol 4 2022.
- [5]. SkAnusha , S Saranya , T Deepthika , V Vamsi Krishna , I Hareesh. "ACCIDENT RESCUE SYSTEM USING GSM,GPS AND NODE MCU". JETIR Volume 10, Issue 4 April 2023.
- [6]. G. Boopathi Raja, Keerthika A, Keerthika S G, Nandhini A, Pranitha K J . "GSM based Vehicle Accident Alert System". IJERT 2021.
- [7]. Muhammad Ahmad Baballe, AminuYau, Sirina Farouk Ibrahim, Abdulmuhamin Muhammad, NajaatuKabir Mustapha. "Accident Detection System with GPS, GSM, and Buzzer". J Math Techniques Comput Math, Volume 2 | Issue 3 | 2023.



- [8]. AmitBhandari, Mukesh Kumar Ojha ,Dilip Kumar Choubey , VaibhavSoni . “IoT Based System for Accident Detection, Monitoring and Landslide Detection Using GSM in Hilly Areas” Research Reports on Computer Science 2023.
- [9]. P. Pradeep, PabbuSusmitha, PadegaPriyanka, ChekkalaVarsha, ParlagollaManjula. “IOT Based Accident Detection and Emergency Alert Device”. Journal of Propulsion Technology (2024)
- [10]. Aayesha.Y, Abinaya. R, Akalya Devi. B, Jeevitha. D .”IoT Based Accident Detection and Management System “. International Journal of Innovative Research in Engineering Volume 4, Issue 3(May-June 2023).

