

Wireless Bluetooth LCD Display

V. H. Kate, Sidra Khan, Anjali Choubey, Swanandi Teni, Gayatri Bhamare

Department of Electronic and Telecommunication
Guru Gobind Singh Polytechnic, Nashik, India

Abstract: Notice board is ideally useful tool for organizing and displaying information, these are used in multitude of businesses such as schools, colleges, railway station etc. In this project, we proposed an advanced wireless notice board in which at any time we can add or remove or alter the message according to our requirement. The main aim of this proposed project is to drastically reduce the cost involved, consume smaller amount of power and help in achieving quality of service. Wireless electronic notice boards are a faster alternative to conventional pin-up type notice boards. In this Project we are going to use a 32x16 LED dot Matrix display module which is also known as P10 LED Display Module to display a Scrolling text by using Arduino UNO.

Keywords: LCD Display, Communication, Bluetooth module

I. INTRODUCTION

In this world Mobile Phones and the related technologies are becoming more and more prevalent. Various technical arenas in the field of Telecommunication and Embedded Systems are becoming omnipresent in the people. The use of cell phones has rapidly increased over the last decade and a half Upgradation in networking technologies has encouraged the development and growth of very dense networks. Notice boards are one of the widely used ones ranging from primary schools to major organizations to convey messages at large. A lot of paper is been used and which is later wasted by the organizations. This in turn leads to a lot of deforestation thus leading to global warming. Small innovative steps in making use of technology for regular purposes would have an adverse effect on the environment issues which we are presently concerned about.

II. LITERATURE REVIEW

[1] Ramya R, Bavithra N, Priyanka M, "Wireless notice board using Bluetooth technology" This paper explains E-notice board with the help of Bluetooth technology.

This document deals with an innovative rather an interesting manner of intimating the message to the people using a wireless electronic display board which is synchronized using the Bluetooth technology. This will help us in passing any message almost immediately without any delay just by sending a SMS which is better and more reliable than the old traditional way of passing the message on notice board. This proposed technology can be used in colleges many public places, malls or big

buildings to enhance the security system and also make awareness of the emergency situations and avoid many dangers.

[2] Dharmendra Kumar Sharma, Vineet Tiwari, "Small and medium range wireless electronic noticeboard using Bluetooth and ZigBee" this paper introduces Notice Board using Bluetooth and ZigBee technology. When information exchange occurs between people via a network, then authentication and security of data have more priority. This paper introduces a low cost, handheld, wireless electronic notice board by using Atmel's ATmega32 microcontroller and different wireless technologies (Bluetooth and ZigBee) and their performance analysis based on the parameter such as range, BER (bit error rate), RSSI (Received signal strength indicator), signal attenuation and power consumption. The notice board receives serial data from wireless module receiver and displays it on the graphical liquid crystal display. We have realized a common communication receiver hardware for notice board having compatibility with both wireless modules i.e., Bluetooth and ZigBee. We used KS0108based128x64graphical

III. PROPOSED METHODOLOGY OF SOLVING IDENTIFIED PROBLEM:

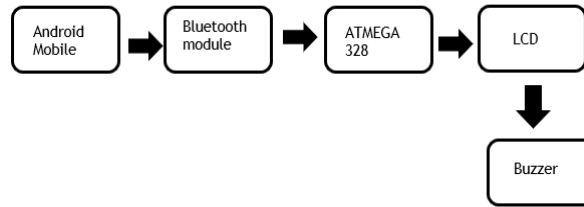

Figure 1 Block Diagram of Proposed System

IV. WORKING

Android mobile consist several mobile app. In those we use an app called as Arduinopedia. This app consists serial box and keypad for instating the data which is to be transmitted. First we selecting Bluetooth module then our communication with the Bluetooth module and mobile phone is start then after entering the data we can press the send button hence mobile send this data to the Bluetooth module After receiving these data Bluetooth module give this to Arduino and then atmega328 displayed on LCD and when next data is come it clear the LCD and again Print new data on that LCD. After sending data Buzzer start its working and announcing the attention sound to alert peoples for the next notice

ATmega328L

Introduction:

The Atmel ATmega8A is a low-power CMOS 8-bit microcontroller based on the AVR enhanced RISC architecture. By executing powerful instructions in a single clock cycle, the ATmega8A achieves throughputs close to 1MIPS per MHz This empowers system designer to optimize the device for power consumption versus processing speed.

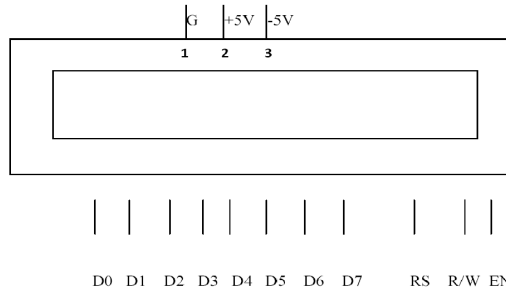

Figure 2.1: PIN DIAGRAM OF LCD DISPLAY

Features

- High-performance, Low-power Atmel AVR 8-bit Microcontroller
 - Advanced RISC Architecture
 - 130 Powerful Instructions - Most Single-clock Cycle Execution
 - 32 x 8 General Purpose Working Registers
 - Fully Static Operation
 - Up to 16MIPS Throughput at 16MHz
 - On-chip 2-cycle Multiplier
 - High Endurance Non-volatile Memory segments
 - 8KBytes of In-System Self-programmable Flash program memory
 - 512Bytes EEPROM
 - 1KByte Internal SRAM
- Write/Erase Cycles: 10,000 Flash/100,000 EEPROM
 – Data retention: 20 years at 85°C/100 years at 25°C(1)

- Optional Boot Code Section with Independent Lock Bits
- In-System Programming by On-chip Boot Program
- True Read-While-Write Operation
- Programming Lock for Software Security

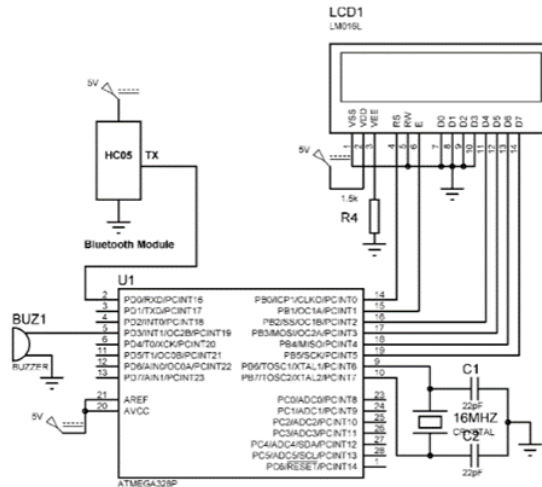

Figure 3 Block Diagram of Bluetooth LCD Display

4.1 Circuit Diagram Description:

As per the circuit diagram we built the circuit connection. After that we upload the program in Arduino then all functions start to run with program. After uploading the program, we will give the external power supply to the Arduino. then we send notice/ SMS from mobile then this notice/SMS will receive Bluetooth and display on LED module. This proposed system used for many upcoming applications in educational institutions and organizations, crime prevention, traffic management, railways, advertisements etc

Pin diagram

Most of the LCD modules conform to a standard interface specification. A 14pin access is provided having eight data lines, three control lines and three power lines. The connections are laid out in one of the two common configurations, either two rows of seven pins, or a single row of 14 pins. One of the pins are numbered on the LCD's print circuit board (PCB), but if not, it is quite easy to locate pin1. Since this pin is connected to ground, it often has a thicker PCB track, connected to and it is generally connected to metalwork at same point.

V. SOFTWARE DETAILS

- Slave default Baud rate: 9600, Data bits:8, Stop bit: 1,Parity:No parity.
- PIO9 and PIO8 can be connected to red and blue led separately. When master and slave are paired, red and blue led blinks 1time/2s in interval, while disconnected only blue led blinks 2times/s.
- Auto-connect to the last device on power as default.
- Permit pairing device to connect as default.
- Auto-pairing PINCODE:"1234" as default.
- Auto-reconnect in 30 min when disconnected as a result of beyond the range of connection.

VI. SPECIFICATIONS

- Typical -80dBm sensitivity.
- Up to +4dBm RF transmit power.
- Low Power 1.8V Operation, 3.3 to 5 V I/O.
- PIO control.

- UART interface with programmable baud rate.
- With integrated antenna.
- With edge connector

Advantages:

1. It requires fewer components so its cost is low.
2. Small in size.
3. Light weight.
4. Flexible users.
5. Easy to operate.

Disadvantages:

- First time installation cost is high.
- Minimum numbers of words can be displayed at a time.
- Electricity is needed.

Application:

1. It is used in various Industries.
2. It is used in hotels.
3. It is used in Colleges and offices.

VII. CONCLUSION

1. This project is most applicable in railways as well as bus transportation for wireless notice board, in banks, schools, colleges etc
 2. Due to wireless complexity from the wired connection between the display and controller is solved
 3. Bluetooth module having range upto 10 meters hence wide range is possible
- Transmitter is out mobile phone hence no need of other transmitter is needed .

REFERENCES

- [1] Ramya R, Bavithra N, Priyanka M “Wireless E-notice board using Bluetooth technology”, IJERT 2018.
- [2] Dharmendra Kumar Sharma, Vineet Tiwari, Krishnan Kumar, et.al, “Small and Medium Range Wireless Electronics Notice Board using Bluetooth and Zig Bee”, IEEE INDICON 2015
- [3] M. Abila Mary, B. Pavithra, R. Sangeetha, Prof.T.C. Subbu Lakshmi “GSM based wireless noticeboards using Arduino”, IJARTET 2019.
- [4] Pooja Pawar, Suvarna Langade, Mohini Bandgar “IOT Based Digital Notice Board using Arduino ATmega328”, IRJET 2019.
- [5] Pallavi M. Banait, Nikita P. Bakale, Mayuri S. Dhakulkar, Bhushan S. Rakhonde “Cost effective Android based wireless notice board”, IJETER 2018
- [6] Gaurav Bhardwaj, Gunjan Sahu, Rajan Kumar Mishra “IOT based smart notice board”, IJERT 2022.