

# Internet of Things (IoT), IoT Protocols and It's Application

**Mrs. Vaishali Nitin Unawane (Khoche)**

Lecturer, MIT Polytechnic, Chh. Sambhajinagar, MH, India.

khoche.vaishu@gmail.com

**Abstract:** *We are entering in a beginning of a new computing technology i.e. Internet of Things (IOT). IOT is a sort of "universal global neural network" in the cloud which connects various devices. The Internet of Things (IoT) is defined as a paradigm in which objects provide with sensors, actuators, and processors communicate with each other to serve a meaningful purpose.*

*The IOT is an intelligently connected devices and systems which be made up of smart machines interacting and communicating with other machines, environments, objects and infrastructures and the Radio Frequency Identification (RFID) and sensor network technologies will go up to meet this new challenge.*

*.The type of communication is either human-to-human or human-to-device, but the Internet of Things (IoT) promises a great future for the internet where the type of communication is machine-to-machine (M2M).[2]*

*The WSN (Wireless Sensor Network) is a central component of the IoT. Wireless sensor networks (WSNs) play an important part in IoT technology.. ZigBee standard is an important WSN and IoT communication protocol in order to facilitate low-power, low-cost IoT applications and to handle numerous network topologies. [1]*

**Keywords:** IoT, IoT Architecture, IoT Protocols, Application of IoT

## I. INTRODUCTION

The Internet of Things (IoT) is an emerging paradigm that enables the communication between electronic devices and sensors through the internet in order to facilitate our lives. IoT use smart devices and internet to provide innovative solutions to various challenges and issues related to various business, governmental and public/private industries across the world.[3] IoT is not limited to just connecting things to the internet but also allow things to communicate and exchange data. IoT may be used for a variety of purposes, including vehicle response, smart buildings, fast medical assistance, and smart cities. A big number of sensors may be replaced by a small number of sensors in current IoT systems, and IoT can be placed on one platform, consuming power and energy.[1]. The main purpose of this paper to give basic information on IoT, architecture of IoT networks which can better explain the meaning and various features of the IoT. By 2020 there will be a total of 50 billion devices /things connected to internet.

The internet of things (IoT) connects various forms of wired and wireless networks to the internet, thus linking objects to each other and forming a huge network for easy monitoring, analysis and control. Wireless sensing technology is widely used in many fields, such as battlefield surveillance, environmental and traffic detection, industrial and agricultural production. In essence, IoT technology is a technology that enables the interconnection of things through modern information networks, enabling the effective exchange and flow of information between items. However, the network environment itself has certain openness, making it extremely easy for people to incur certain economic losses due to network risks in the application of IoT technology.[6]

## II. ARCHITECTURE OF IOT

### Three layer Architecture of IoT

As shown the Figure 2.1, any or all of these components plays an important role in the IoT's overall structure.

**Perceptual layer:** in an IoT system, temperature, operating status and other relevant parameters need to be collected through the sensing layer. When certain parameters reach a preset range, the IoT remote control is activated. For example, in an IoT-based warehouse management system, the site environment is detected by an

infrared temperature measuring device, but an alarm is issued when a fire is detected and a water spray is activated;

**Network layer:** the IoT system’s skeleton is made up of the network transport layer. All types of networks, such as the internet, ethernet and mobile networks can be used as network transport layers. The information obtained from the sensing layer and the control commands communicated to the actuators need to be transmitted through the network layer of transmission;

**Application layer:** the applying layer consists of two parts: a software system for processing information and a web page or mobile app for human control. The application layer integrates intelligent information processing technologies such as distributed computing and cloud computing. The data and information transmitted from the network transmission layer is concentrated in the application layer system for processing, and the system is equipped with functions such as addressing, command issuance, security control and data storage. In addition, the application layer has an extension interface to enable the expansion of new functions.[6]

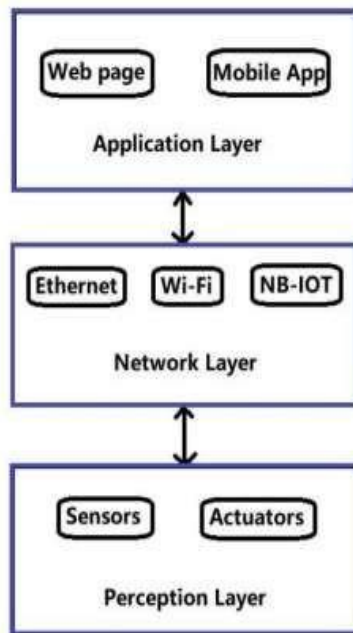

Figure 2.1. Architecture of IoT

Four Layer architecture of IoT

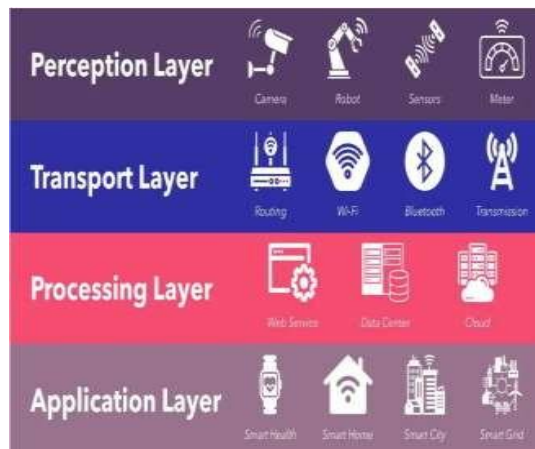

Figure. 2.2 Four layer Architecture of IoT

IoT Protocols

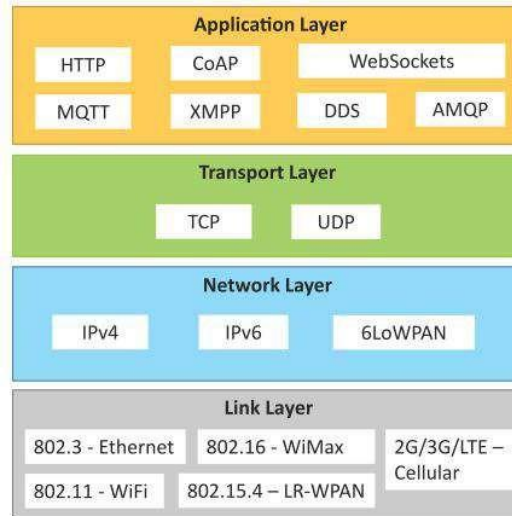

Figure 3.1 Protocols in each layer

**IoT Protocols:**

**Link Layer :** Protocols determine how data is physically sent over the network's physical layer or medium. Local network connect to which host is attached. Hosts on the same link exchange data packets over the link layer using link layer protocols. Link layer determines how packets are coded and signaled by the h/w device over the medium to which the host is attached.

Protocols:

**802.3-Ethernet:** IEEE802.3 is collection of wired Ethernet standards for the link layer. Eg:

802.3 uses co-axial cable; 802.3i uses copper twisted pair connection; 802.3j uses fiber optic connection; 802.3ae uses Ethernet over fiber.

**802.11-WiFi:** IEEE802.11 is a collection of wireless LAN(WLAN) communication standards including extensive description of link layer. Eg: 802.11a operates in 5GHz band, 802.11b and 802.11g operates in 2.4GHz band, 802.11n operates in 2.4/5GHz band, 802.11ac operates in 5GHz band, 802.11ad operates in 60Ghzband.

**802.16 - WiMax:** IEEE802.16 is a collection of wireless broadband standards including exclusive description of link layer. WiMax provide data rates from 1.5 Mb/s to 1Gb/s.

**802.15.4-LR-WPAN:** IEEE802.15.4 is a collection of standards for low rate wireless personal area network(LR-WPAN). Basis for high level communication protocols such as ZigBee Provides data rate from 40kb/s to 250kb/s.

**2G/3G/4G-Mobile Communication:** Data rates from 9.6kb/s(2G) to up to 100Mb/s(4G).

**Network/Internet Layer:** Responsible for sending IP datagrams from source n/w to destination n/w. Performs the host addressing and packet routing. Datagrams contains source and destination address.

Protocols:

**IPv4:** Internet Protocol version4 is used to identify the devices on a n/w using a hierarchical addressing scheme. 32 bit address. Allows total of  $2^{32}$  addresses.

**IPv6:** Internet Protocol version6 uses 128 bit address scheme and allows  $2^{128}$  addresses.

**6LOWPAN:** IPv6over Lowpower Wireless PersonalAreaNetwork) operates in 2.4 GHz frequency range and data transfer 250 kb/s.

**Transport Layer:** Provides end-to-end message transfer capability independent of the underlying n/w. Set up on connection with ACK as in TCP and without ACK as in UDP. Provides functions such as error control, segmentation, flow control and congestion control.

Protocols:

**TCP:** Transmission Control Protocol used by web browsers (along with HTTP and HTTPS), email (along with SMTP, FTP). Connection oriented and stateless protocol. IP Protocol deals with sending packets, TCP ensures reliable transmission of protocols in order. Avoids n/w congestion and congestion collapse.

**UDP:** User Datagram Protocol is connectionless protocol. Useful in time sensitive applications, very small data units to exchange. Transaction oriented and stateless protocol. Does not provide guaranteed delivery.

**Application Layer:** Defines how the applications interface with lower layer protocols to send data over the n/w. Enables process-to- process communication using ports.

Protocols:

**HTTP:** Hyper Text Transfer Protocol that forms foundation of WWW. Follow request- response model Stateless protocol.

**CoAP:** Constrained Application Protocol for machine-to-machine (M2M) applications with constrained devices, constrained environment and constrained n/w. Uses client- server architecture.

**Web Socket:** allows full duplex communication over a single socket connection.

**MQTT:** Message Queue Telemetry Transport is light weight messaging protocol based on publish-subscribe model. Uses client server architecture. Well suited for constrained environment.

**XMPP:** Extensible Message and Presence Protocol for real time communication and streaming XML data between network entities. Support client-server and server-server communication.

**DDS:** Data Distribution Service is data centric middleware standards for device-to-device or machine-to-machine communication. Uses publish-subscribe model.

**AMQP:** Advanced Message Queuing Protocol is open application layer protocol for business messaging. Supports both point-to-point and publish-subscribe model.

Application areas of IoT

The various application areas of WSNs in IoT and the contribution of WSNs in the field are described in detail. These applications are military, agricultural field, medical care, and transportation. The explanations of these applications are provided as follows.



Fig.4.1 Application of IoT

**Military:** WSN technology is stealthy, self-organisable and highly fault-tolerant, which helps sensors to function in dangerous battlefield environments. In the military field, the artillery target area is covered by a huge number of sensor nodes that are deployed using wireless sensor network technology, aircraft and other launchers.

**Agricultural field:** WSN has the advantages of dense distribution, simple deployment, and easy communication can be in the agricultural sector in real-time monitoring of soil environmental conditions, livestock environmental conditions, crop growth, large and cumulative surface characteristics. In addition, wireless sensor network technology combined with mature global positioning system (GPS) technology, internet technology, can establish a dynamic real-time

management platform, through wireless sensors to monitor the crop growth environment, analysis of crop quality and the relationship between the growth environment, and thus achieve precision agriculture, intelligent farming purposes

**Medical care:** with the ageing of the population, medical care for patients is now an issue that must be addressed. Wireless sensor network technology is playing an important role in the medical care sector. Doctors can place various sensors on patients to detect and collect physiological information such as blood pressure, respiration and temperature in real time, so that they can understand the development of the patient's condition in real time and use the physiological information collected as a reference for drug development. In addition, multiple sensor nodes can be installed in the patient's living environment to monitor the patient's activities remotely in real time, so that the patient can be assisted in the event of a problem.

**Transportation:** with the improvement of people's quality of life, the increasing number of private cars and the rapid development of the logistics industry, traditional traffic systems have become obsolete and intelligent transportation has come into being. WSN enable real-time monitoring of traffic conditions. By placing sensors on the road to monitor vehicles and centrally analyzing the road conditions, the flow of traffic on each route segment can be measured, thus providing the best route for the traveler to take in order to increase the effectiveness of traffic management and lessen traffic congestion.[6]

### III. CONCLUSION

The concept of IoT is for a long area of research, in this paper introduction about IOT technology we also understand that not only a smart phone, tablets, and laptops are part of IoT other many devices also part of IoT like lightning device, Air condition.

In this paper given different types protocol used in different IoT application based on particular application. We can design different application like in agriculture automation, home automation, warehouse, also design application for automobile, in health care system, transportation, military.

### REFERENCES

- [1]. "Internet of things based wireless sensor Network": a review Article *in* Indonesian Journal of Electrical Engineering and Computer Science · July 2022
- [2]. "A Review Paper on Internet of Things (IoT) And it's Applications. Authors Name:Mrs. Sarika A.Korade1, Dr. Vinit Kotak2, Mrs. Asha Durafe3. International Research Journal of Engineering and Technology (IRJET) e-ISSN: 2395-0056 Volume: 06 Issue: 06 | June 2019
- [3]. "Internet of Things is a revolutionary approach for future technology enhancement: a review". Authors Name: Sachin Kumar1\* , Prayag Tiwari2 and Mikhail Zymbler1
- [4]. "Internet of Things (IoT): Definitions, Challenges, and Recent Research Directions" Article *in* International Journal of Computer Applications · October 2015
- [5]. "Internet of things based wireless sensor network: a review" Article in Indonesian Journal of Electrical engineering and Computer science- July 2022.
- [6]. "Wireless sensor networks in the internet of things: review, techniques, challenges, and future directions" Article *in* Indonesian Journal of Electrical Engineering and Computer Science. August 2023, Indonesian Journal of Electrical Engineering and Computer Science Vol. 31, No. 2, August 2023, pp. 1190~1200, ISSN: 2502- 4752