

# Design and Development of Floor Cleaner Robot

**Ms. Minal Amrutkar, Ms. Jagruti Chaudhari and Mr. Pranav Deshpande**

Student, Department of Electronics and Telecommunication

Maratha Vidya Prasarak Samaj's, Karmaveer Baburao Ganpatrao Thakrey College of Engineering, Nashik

**Abstract:** *It's a wireless Bluetooth control floor cleaning machine and will be amazed at the simplicity and effectiveness of the idea. It's basically DC motors wired in a wheeled plastic container with a cleaning solution placed on top and a scrub attached in the bottom through one of the motors. Anybody can operate this machine easily. Hence it is very useful in hospitals, houses, etc. Bluetooth module is used for controlling the entire system with help of remote or mobile. There is an application in mobile for Bluetooth connection between the system and mobile. By using Bluetooth module, we can direct and turn the system as the user needs. It works great and controlled manually based on the user convenience. Definitely makes cleaning easier and merrier while enabling anyone to build something rather than buy. In modern days interior decorations are becoming an important role in our life. Cleaning of floor is a very important one for our health and reduces the man power requirement. Hence our project is very useful in our day to day life.*

**Keywords:** Automatic, floor Cleaning, machine, Bluetooth, prototype

## I. INTRODUCTION

### 1.1 Need of Project

Robots are machines which are programmable and are able to carry out complex tasks with minimal human interventions. In the recent years, robots have been used for various cleaning purposes. Robots have various cleaning expertise like mopping, picking up the waste, wet floor cleaning, dry vacuum cleaning etc., Depending on the cleaning mechanism, these robots may have some advantages and disadvantages.

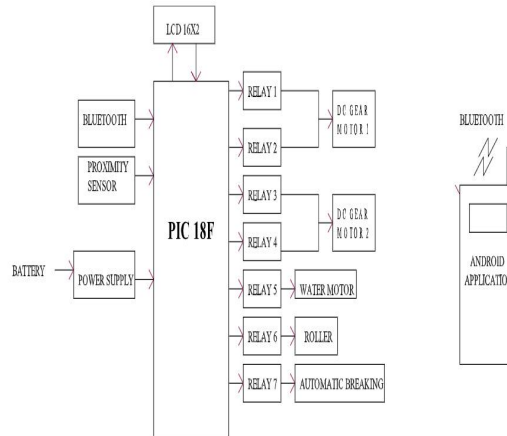
This robot on receiving the commands from the android device cleans the area using a cleaning pad by spraying water on the floor. After cleaning the wet floor, it can drain the dirty water into the required container as per the commands given to it. The robotic arm is used for efficient and effective wet floor cleaning purpose. This system can also be used to pick up the objects and carry them within the Bluetooth range. The proposed system is a manual system because it is controlled by android application which is operated by human.

### 1.2. Motivation:

Manual cleaning is a very hectic and very hard working process especially when it comes to hospital and school/colleges corridors. During the manual cleaning operation some dust and dirt particle may remain on the floor which tends to more manual effort. With the help of manual cleaning it cannot possible to remove all the water from the surface of the floor which creates slippery surface and which may increase the chances of accidents.

The motivation behind this idea was to make a to make a cleaning robot which is autonomous as well as manual featured and user friendly. In schools, colleges, hospitals there is too much load on workers to always keep floors clean. To reduce their stress, we are coming with an idea of floor cleaning robot with automatic and manual working. So because of this the workload of workers will get reduce and they can operate it manually or automatically. Anybody can operate this machine easily.

**II. BLOCK DIAGRAM**



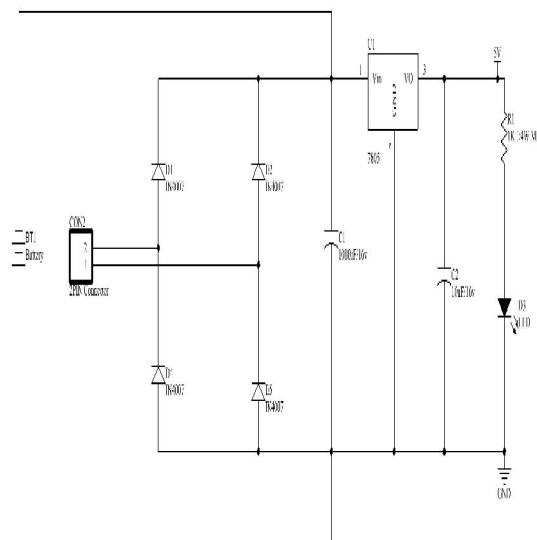
**2.1 Block Diagram Explanation**

In this project a robot is develop which operate on Bluetooth sensor. Here automatic braking system is used to stop the robot when any obstacle comes in front of robot.

There are two modes of robot namely automatic and manual. There are switches provide for automatic and manual mode. In manual mode robot is applied through Bluetooth if any obstacle is detected then robot should stop. In automatic mode robot continuously move and cleaning the floor and if any obstacle is detected then robot should stop and take turn. There are two tanks used one is for clean water and other is for waste water. Robot first sprinkle the water in floor through sprinkler motor and then roller will be move to clean the floor and the waste water is suck in waste water tank. In this project a robot is develop which operate on Bluetooth sensor. Here automatic braking system is used to stop the robot when any obstacle comes in front of robot.

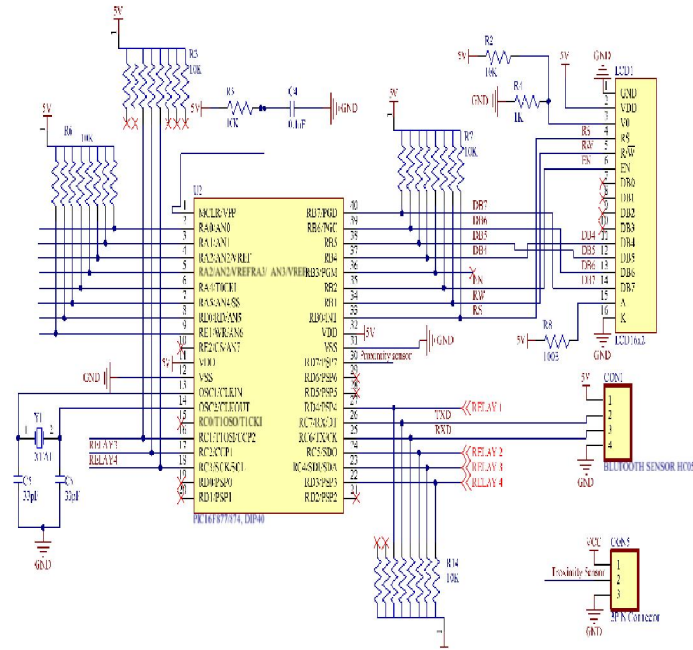
There are two tanks used one is for clean water and other is for waste water. Robot first sprinkle the water in floor through sprinkler motor and then roller will be move to clean the floor and the waste water is suck in waste water tank.

**2.2. Circuit Diagram**



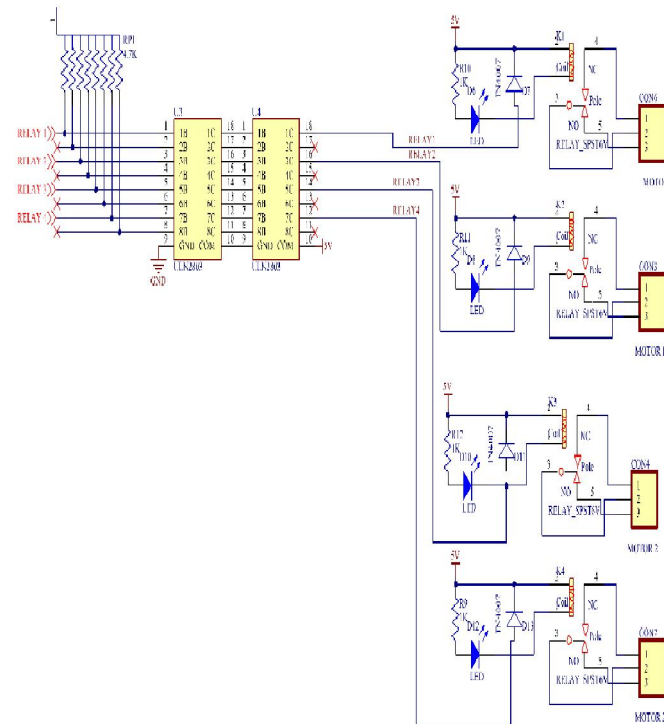
**Figure 4.1:** Design of Power Supply

**2.3 Main Circuit:**



**Figure 4.2: Main Circuit Diagram**

**2.3 Relay Circuit**

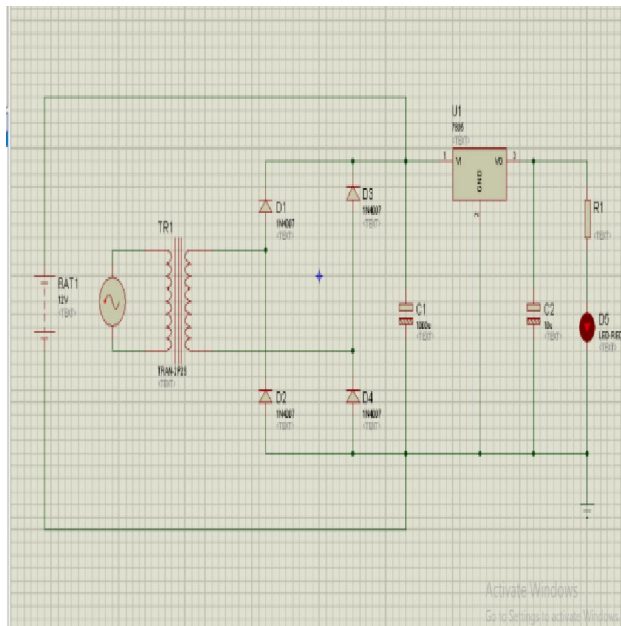


**Figure 4.3: Circuit Diagram of Relay**

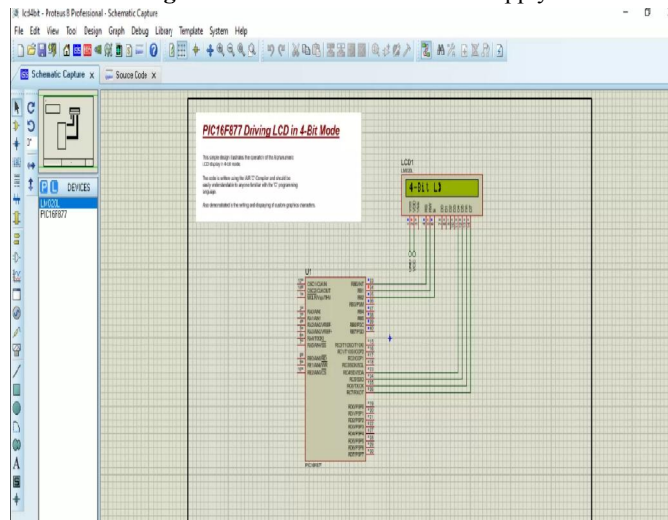
**III. CIRCUIT DIAGRAM EXPLANATION**

We use PIC16F877A this is PIC Microcontroller 40 pin IC DIP socket. It is 8-bit PIC Microcontroller, operating voltage is 2 to 5.5 V. It has 368 bytes of RAM ,256 bytes of data EEPROM.LCD is connected it is of 4-bit mode. For controlling brightness and contrast there are R8 R2,R4. There is reset circuit and also pull up resistor of 10 k for current sinking and sourcing purpose. There is Bluetooth sensor HC05 connected to Txd, Rxd it required 5 V. We use relay ULN2803, relay required 200 mA & controller provide only 1mA current and motor turns on at 500 mA. So this is current booster IC. We use 2 IC for invert logic. Supply current from regulated IC of 5V. There is free wheeling diode for electromagnetic relay single pole double throw. When relay on & off reverse current is generated from the coil & diode will protect that current.

**IV. SIMULATION**

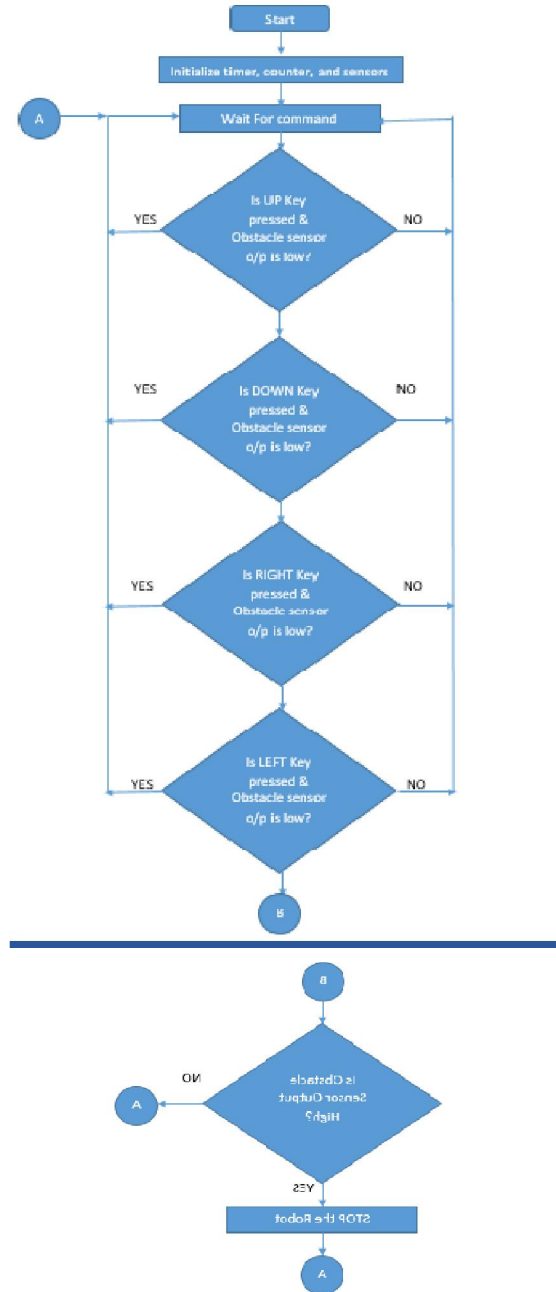


**Figure 4.1: Simulation of Power Supply**

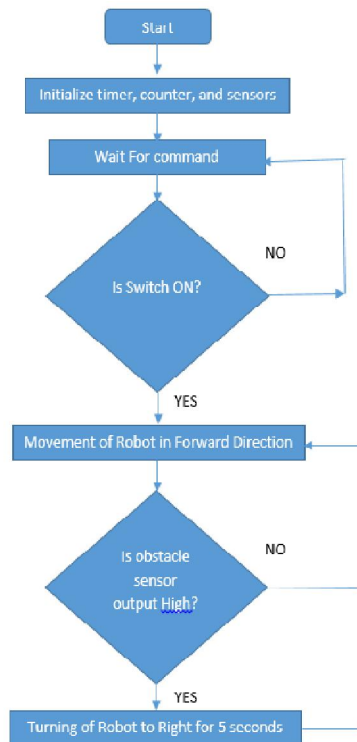


**Figure 4.2: LCD interfacing using PIC**

**V. FLOWCHART**



**Figure 5.1: Manual Mode**



**Figure 5.2:** Automatic mode

#### VI. ADVANTAGES

1. Minimizes human efforts to clean the floor.
2. Easy to move.
3. Wet Cleaning and dry cleaning the floor.
4. Robot will detect the obstacle.
5. Wireless remote control operation via Bluetooth.

#### VII. APPLICATIONS

1. Main Application of This Project Is Cleaning.
2. Time Can Be Saved by Using This Robot.
3. Can Be Used in Hospitals, Schools, Colleges, Industries and etc.

#### VIII. CONCLUSION

We have successfully studied the requirement of Robot for floor cleaning purpose. In this project, we will be developing a robot which uses PIC 16F microcontroller. We will have 2 modes i.e. Automatic mode and manual mode. The robot will be monitored using Bluetooth device connected to it. Whenever obstacle is detected in front of the robot, it will automatically stop and turn to the provided direction.



#### REFERENCES

- [1]. Manreet Kaur, Preeti Abrol “Design and Development of Floor Cleaner Robot (Automatic and Manual)” *International Journal of Computer Applications (0975 – 8887)* Volume 97– No.19, July 2014.
- [2]. Manya Jain, Pankaj Singh Rawat “Automatic Floor Cleaner” *International Research Journal of Engineering and Technology (IRJET)* Volume: 04 Issue: 04 | Apr -2017 e-ISSN: 2395 -0056 p-ISSN: 2395-0072.
- [3]. IEEE Standard for User Interface Elements in Power Control of Electronic Devices employed in Office/Consumer Environments, IEEE Standard 1621,2004(R2009).
- [4]. Michael Dooley, James Philip Case, and Nikolai Romanov, “System and method for autonomous mopping of a floor surface,” U. S. Patent 8 892 251 B1, November 18, 2014.
- [5]. Jagdeesh Chandra A. P, Venugopal C.R, Novel Design solutions for remote access acquire and control of Laboratory experiments on DC machines, *IEEE transaction on instrumentation and measurement*, 61, 2, 2012.